

**EM ready2apply PRO 2 W**

EM ready2apply

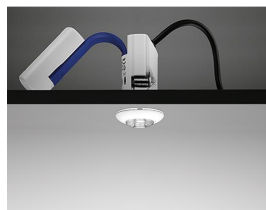

**Product description**

- \_ LED emergency module suitable for direct installation in ceilings
- \_ Complete set with integrated electronics, LED module, heat sink, optics and battery
- \_ Includes click-in multi-lens option for anti-panic, escape route and spot illumination
- \_ DALI interface and automatic test function
- \_ Small size ceiling hole, 40 – 43 mm diameter, 80 mm height
- \_ EM = Emergency

**Properties**

- \_ Output power 1.5 W
- \_ Very low stand-by power loss
- \_ White or black housing colour options
- \_ Non-maintained variants
- \_ 1, 2 or 3 h rated duration (separate variants)
- \_ Plug-in Lithium Iron Phosphate battery with strain-relief
- \_ 5 years guarantee electronic (LED driver) (conditions at <https://www.tridonic.com/manufacture-guarantee-conditions>)
- \_ 5 years guarantee for LiFePO4 batteries (conditions at <https://www.tridonic.com/manufacture-guarantee-conditions>)

**Website**

<http://www.tridonic.com/89800542>



**EM ready2apply PRO 2 W**

EM ready2apply

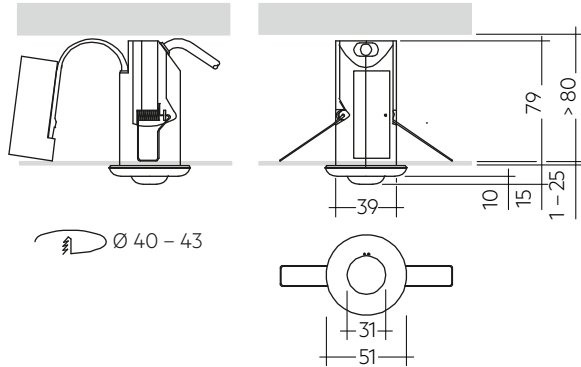

**Ordering data**

Type	Article number	Colour	Operating mode	Rated duration	Number of cells	Packaging, carton	Packaging, pallet	Weight per pc.
EM R2A PRO NM 111 2W	89800542	White	Non-maintained	1 h	1	1 pc(s).	380 pc(s).	0.19 kg
EM R2A PRO NM 132 2W	89800544	White	Non-maintained	3 h	2	1 pc(s).	380 pc(s).	0.23 kg
EM R2A PRO NM 122 2W	89800546	White	Non-maintained	2 h	2	1 pc(s).	380 pc(s).	0.23 kg
EM R2A PRO M 122 2W	89800547	White	Maintained	2 h	2	1 pc(s).	380 pc(s).	0.23 kg
EM R2A PRO NM 132 2W B	89801053	Black	Non-maintained	3 h	2	1 pc(s).	380 pc(s).	0.23 kg

**Technical data**

Rated supply voltage	220 – 240 V
Input voltage range AC (tolerance for safety)	198 – 264 V
Input voltage range AC (tolerance for performance)	198 – 254 V
Mains frequency	50 / 60 Hz
Overvoltage protection	320 V (for 48 h)
Starting time (Emergency operation)	< 0.5 s from detection of emergency event
THD normal operation (maintained operation, at 230 V, 50 Hz, charging)	75 %
Output current tolerance	+ 5 %
LF current ripple	+ 5 %
Ambient temperature ta	5 ... +30 °C
Mains voltage changeover threshold	According to EN 60598-2-22
Type of protection	IP20
Impact protection rating <sup>①</sup>	IK03
Protection class	II
Colour temperature	6,500 K
Colour tolerance	3 SDCM
Colour rendering index CRI	> 80
Lifetime	up to 50,000 h
EoFI	1

**Approval marks**



**Standards**

according to EN 50172, EN 55015, EN 60068-2-29, EN 60068-2-30, EN 60068-2-64, EN 60598-1, EN 60598-2-2, EN 60598-2-22, EN 61000-3-2, EN 61347-1, EN 61347-2-7, EN 61347-2-13, EN 61547, acc. to EN 62034, EN 62384, EN 62386-101, EN 62386-102, DALI standard EN 62386-202, IEC 62133 (related to Lithium Iron battery), UN 38.3 (related to Lithium Iron battery), EN 62031, EN 62471

## Specific technical data

Type	Number of battery cells	Rated duration	Mains current (230 V, 50 Hz), maintained		Mains current (230 V, 50 Hz), non-maintained		Mains power (230 V, 50 Hz), maintained		Mains power (230 V, 50 Hz), non-maintained		Typ. $\lambda$ (at 230 V, 50 Hz, charging)	Typ. output current	Typ. forward voltage	Output power
			Charging	Charger off	Charging	Charger off	Charging	Charger off	Charging	Charger off				
<b>Normal operation</b>														
EM R2A PRO NM 111 2W	1	1 h	-	-	15 mA	10 mA	-	-	1.5 W	0.6 W	0.42C	-	-	-
EM R2A PRO NM 132 2W	2	3 h	-	-	20 mA	10 mA	-	-	2.5 W	0.6 W	0.50C	-	-	-
EM R2A PRO NM 122 2W	2	2 h	-	-	20 mA	10 mA	-	-	2.5 W	0.6 W	0.50C	-	-	-
EM R2A PRO M 122 2W	2	2 h	40 mA	26 mA	20 mA	10 mA	5.5 W	3.2 W	2.5 W	0.6 W	0.58C	126 mA	12 V	1.5 W
EM R2A PRO NM 132 2W B	2	3 h	-	-	20 mA	10 mA	-	-	2.5 W	0.6 W	0.50C	-	-	-
<b>Emergency operation</b>														
EM R2A PRO NM 111 2W	1	1 h	-	-	-	-	-	-	-	-	-	126 mA	12 V	1.5 W
EM R2A PRO NM 132 2W	2	3 h	-	-	-	-	-	-	-	-	-	126 mA	12 V	1.5 W
EM R2A PRO NM 122 2W	2	2 h	-	-	-	-	-	-	-	-	-	126 mA	12 V	1.5 W
EM R2A PRO M 122 2W	2	2 h	-	-	-	-	-	-	-	-	-	126 mA	12 V	1.5 W
EM R2A PRO NM 132 2W B	2	3 h	-	-	-	-	-	-	-	-	-	126 mA	12 V	1.5 W

① IK rating valid for lens

LiFePO4 Battery pack 1.5 – 3.0 Ah

Accessory



**Product description**

- \_ Lithium Iron Phosphate replacement battery pack for use with EM ready2apply emergency lighting units
- \_ 8 year design life (up to 30 °C ambient temperature)
- \_ 5 years guarantee (conditions at <https://www.tridonic.com/manufacture-guarantee-conditions>)

**Properties**

- \_ Certified quality manufacturer
- \_ Casing material made of polycarbonate
- \_ Charge efficiency > 90 %
- \_ Low self discharge
- \_ Compact connector providing polarity safe battery connection
- \_ Protection and monitoring circuit built into battery enclosure
- \_ Battery protected against operation at excessive temperatures
- \_ Deep discharge protection
- \_ Suitable for emergency lighting equipment as per IEC 60598-2-22

**Website**

<http://www.tridonic.com/89800555>



LiFeGuard

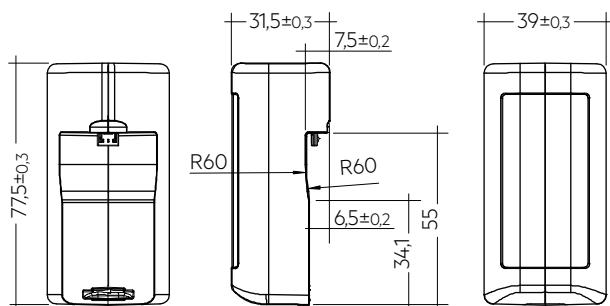

**Ordering data**

Type	Article number	Capacity	Packaging, carton	Weight per pc.
<b>1.5 Ah battery pack</b>				
PACK-LiFePO4 1.5Ah R2A	89800555	1.5 Ah	75 pc(s).	0.064 kg
<b>3.0 Ah battery pack</b>				
PACK-LiFePO4 3.0Ah R2A	89800556	3.0 Ah	75 pc(s).	0.104 kg

**1. Standards**

according to EN 50172  
 EN 55015  
 EN 60068-2-6  
 according to EN 60068-2-30  
 EN 60598-1  
 EN 60598-2-2  
 EN 60598-2-22  
 EN 61000-3-2  
 EN 61347-1  
 EN 61347-2-7  
 EN 61347-2-13  
 EN 61547  
 according to EN 62034  
 EN 62384  
 EN 62386-101  
 EN 62386-102  
 EN 62386-202  
 IEC 62133 (related to Lithium Iron battery)  
 UN 38.3 (related to Lithium Iron battery)  
 EN 62031  
 EN 62471

**1.1 Glow-wire test**

according to EN 60598-1 with increased temperature of 850 °C passed.

**2. Thermal data**

**2.1 Temperature range**

According to the standard IEC 60598-1 a LED Driver for remote installation has a max. case temperature of 90 °C. The ambient temperature range  $t_a$  for the EM R2A PRO is defined to meet this requirement.

**2.2 Expected lifetime**

2.2.1 Electronics

Average lifetime 50,000 hours under rated conditions with a failure rate of less than 10 %. Average failure rate of 0.2 % per 1000 operating hours.

**Expected lifetime**

Type	$t_a$	25 °C	30 °C	40 °C
EM R2A PRO	lifetime	> 50,000 h	50,000 h	50,000 h

2.2.2 Lifetime, lumen maintenance and failure rate for LED module

The light output of an LED module decreases over the lifetime, this is characterized with the L value.

L70 means that the LED module will give 70 % of its initial luminous flux. This value is always related to the number of operation hours and therefore defines the lifetime of an LED module.

As the L value is a statistical value the lumen maintenance may vary over the delivered LED modules.

The B value defines the amount of modules which are below the specific L value, e.g. L70B10 means 10 % of the LED modules are below 70 % of the initial luminous flux, respectively 90 % will be above 70 % of the initial value.

Lifetime declarations are informative and represent no warranty claim.

$t_a$ temperature	L90 / B50	L80 / B50	L70 / B10
25 °C	50,000 h	-	50,000 h
30 °C	-	50,000 h	-
40 °C	-	50,000 h	-

**2.3 Storage conditions**

- Humidity 45 % up to max. 85 %, not condensed (max. 56 days/year at 85 %)
- Storage time / temperature: max. 6 months at -20 °C up to +45 °C (< 3 months at +45 °C)

Note: The devices have to be within the specified temperature range ( $t_a$ ) before they are operated.

- Store batteries within the specified temperature range in low humidity conditions. Optimal storage conditions are:
  - Temperature: -20 ... +25 °C for up to 12 months
  - 20 ... +35 °C for up to 6 months
  - Relative humidity: 65 % ±5 %
- Avoid atmosphere with corrosive gas
- Disconnect batteries before store or delivery
- Avoid storage of discharged batteries

**3. Installation / Wiring**

**3.1 Lens assembly**

- Wear gloves when mounting the lens
- Take care of the mounting direction of the escape route lens
- Use screwdriver for replacing/removing lens
  1. + 2. Push lens clips with screwdriver via openings on both sides
  3. Remove lens

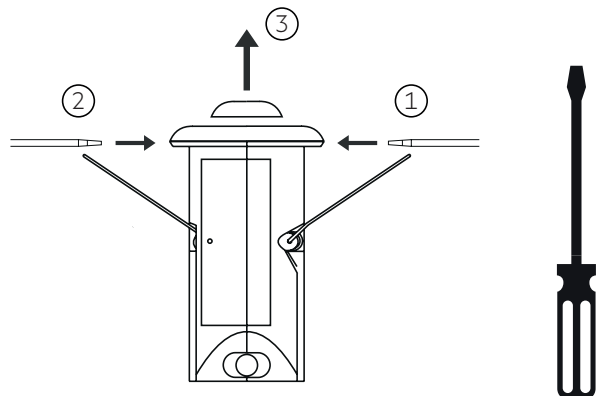

### 3.2 Wiring diagram

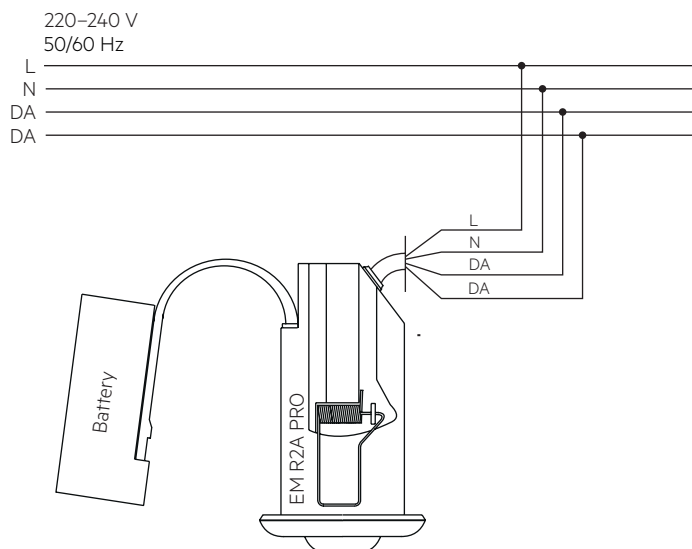

Note: Battery must be connected before mains connection.

### 3.3 Wiring type and cross-section

#### Wiring

Mains (N, L): brown, blue

DALI (DA, DA): orange, orange

Cable length: 250mm with strain relief at the R2A PRO module

Cable: low smoke, halogen free

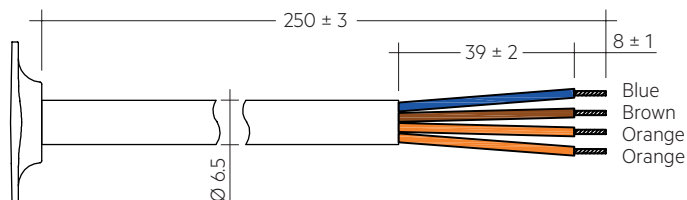
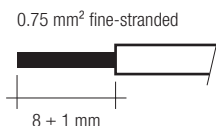

Recommended connector with strain-relief (plug and socket): to be defined

No terminal block included. The installation of the terminal block has to be done by a qualified person.

Only a terminal complying with EN 60998-2-1 or EN 60998-2-2 shall be used

Note: If mains cable or battery strap are damaged the luminaire must be disposed.

## 5. Electrical data

### 5.1 Maximum loading of automatic circuit breakers

Automatic circuit breaker type	C10	C13	C16	C20	B10	B13	B16	B20	Inrush current
Installation Ø	1.5 mm <sup>2</sup>	1.5 mm <sup>2</sup>	2.5 mm <sup>2</sup>	4 mm <sup>2</sup>	1.5 mm <sup>2</sup>	1.5 mm <sup>2</sup>	2.5 mm <sup>2</sup>	4 mm <sup>2</sup>	I <sub>max</sub> time
<b>EM R2A PRO</b>	180	260	260	260	90	130	130	130	10 A 120 µs

### 5.2 Harmonic distortion in the mains supply (at 230 V / 50 Hz and 2-cell maintained charging) in %

	THD	3.	5.	7.	9.	11.
<b>EM R2A PRO</b>	< 75	< 62	< 33	< 19	< 18	< 13

## 4. Mechanical data

### 4.1 Housing properties

- Polycarbonate white RAL 9016
- Polycarbonate black RAL 9005

### 4.2 Battery connection

Battery pack end termination

Compact micro USB type B connector providing safe battery connection

Module end termination

- Battery strap with compact micro USB type B connector
- Strain relief at the module casing and locking clip for secure connection of the battery pack
- Battery strap: low smoke, halogen free

Note: Strap not suitable for connection of any other micro USB device other than the ready2apply battery pack

### 4.3 Fixing

Spring fixing through hole in ceiling

- Hole diameter: 40 – 43 mm
- Ceiling thickness: 1 – 25 mm
- Ceiling void height: > 80 mm

### 5.3 Insulation matrix

	Mains	Battery	DALI
Mains	-	••	•
Battery	••	-	•
DALI	•	•	-

- Represents basic insulation
- Represents double or reinforced insulation

DALI terminals are not SELV. Wire the terminals in accordance with the requirements of low voltage installations.

### 5.4 Battery charge regime / discharge

#### EM R2A PRO 2 W, 1 / 2 / 3 h

Type	EM R2A PRO 2 W	EM R2A PRO 2 W	
	Article no.	89800542	89800544 / 89800546 / 89801053
Cells	1 cells	2 cells	
Duration	1 h	2 / 3 h	
Battery charge time	Initial	20 h	
	Recharge	12 h	
	Trickle charge	continuously and battery voltage controlled	
Typ. charge current <sup>®</sup>	Initial charge	140 mA	290 mA
	Recharge	140 mA	290 mA
	Trickle charge	140 mA / 0 mA	290 mA / 0 mA
Mains power consumption	Initial charge	< 1.095 W	< 1.095 W
	Recharge	< 1.095 W	< 1.095 W
	Trickle charge	< 1.095 W / 0 W	< 1.095 W / 0 W
Discharge current at 3.2 V (nominal)	625 mA	625 mA	

<sup>®</sup> Automatic recharge when battery voltage falls below 3.4 V. Charger off (0 mA) when battery voltage exceeds 3.6 V.

Note: Battery protected against operation at excessive temperatures (charging stopped when battery cell temperature < 0 °C or > 60 °C)

### 5.5 Battery selection for replacement

#### EM R2A PRO 2 W, 1 / 2 / 3 h

		Type	EM R2A PRO 2 W	EM R2A PRO 2 W	
		Article no.	89800542	89800544 / 89800546 / 89801053	
		Cells	1 cells	2 cells	
		Duration	1 h	2 / 3 h	
Technology and capacity	Design	Number of cells	Type	Article no.	Assignable batteries
Lithium Iron Phosphate 1.5 Ah	single cell	1	PACK-LiFePO4 1,5Ah R2A	89800555	•
Lithium Iron Phosphate 3 Ah	side by side	1 + 1	PACK-LiFePO4 3,0Ah R2A	89800556	•

Note: If the rated duration of operation cannot be reached the battery must be replaced. Remove mains during battery replacement.

## 6. Interfaces / communication

### 6.1 Control input (DALI DT1)

The control input is non-polar for digital control signals (DALI). The control signal is not SELV. Control cable has to be installed in accordance to the requirements of low voltage installations.

## 7. Functions

### 7.1 Status indication

System status is indicated by a bi-colour LED and by a DALI status flag. The indication LED is integrated in the bezel.

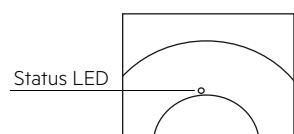

LED indication	Status	Comment
Permanent green	System OK	AC mode
Fast flashing green (0,1 sec on – 0,1 sec off)	Function test underway	
Slow flashing green (1 sec on – 1 sec off)	Duration test underway	
Red LED on	Load failure	Open circuit / Short circuit / LED failure
Slow flashing red (1 sec on – 1 sec off)	Battery failure	Battery failed the duration test or function test / Battery is defect or deep discharged / Incorrect battery voltage / Battery is outside of its temperature range for charging (0 – 60 °C)
Fast flashing red (0,1 sec on – 0,1 sec off)	Charging failure	Incorrect charging current
Double pulsing green	DALI Inhibit	Switching into DALI inhibit mode via controller
Binary transmission of address via green/red LED	Address identification	During address identification mode
Green and red off	DC mode	Battery operation (emergency mode)

### 7.2 Testing

Emergency operation can be manually tested by removal of the mains supply.

#### DALI Control

A DALI command from a suitable control unit can be used to initiate function and duration tests at individually selected times. Status flags are set for report back and data logging of results.

When a DALI bus has not been connected or when a DALI bus is connected but the DALI default DELAY and INTERVAL times have not been re-set by sending appropriate DALI commands, then the EM R2A PRO will conduct self-tests in accordance with the default times set within the EEPROM. These default times are factory pre-set, in accordance with the DALI standard EN 62386-202, to conduct an automatic function test every 7 days and a duration test every 52 weeks. Since the DELAY time is factory pre-set to Zero, all units are tested at the same time. Test times can be changed with a command over the DALI bus.

The DELAY and INTERVAL time values must be re-set when the emergency system test times are to be scheduled by a DALI control and monitoring system.

Note that once the default values have been set to Zero, tests will only be conducted following a command from the control system. If the DALI bus is disconnected the EM R2A PRO does not revert to self-testing mode.

Note: If the battery is connected the DALI communication is only possible after power reset.

#### Commissioning

After installation of the luminaire and initial connection of the mains supply and battery supply to the EM R2A PRO the unit will commence charging the batteries for 20 hours (initial charge). Afterwards the module will conduct a commissioning test for the full duration. The 20 hours recharge occurs also if a new battery is connected or the module exits the rest mode condition. The following automatic commissioning duration test is only performed when a battery is replaced and fully charged (after 20 hrs) and the interval time is not set to zero, otherwise the system is expected to perform the testing.

#### Functional test

The time of day and frequency of the 5 seconds function test can be set by the DALI controller. The default setting is a 5 seconds test on a weekly basis.

#### Duration test

The time of day and frequency of the duration test can be set by the DALI controller. The default setting is a duration test conducted every 52 weeks.

For 2 h operation:

The first commissioning duration test has a time of 120 minutes, subsequent through life tests are conducted for 90 minutes. When the battery is changed or disconnected and re-connected the unit will next conduct a 120 minute test.

#### Timer reset functionality

The timer for function and duration test can be set to a particular time of the day by cycling the unswitched line supply 5 times within 1 minute. The timer adjustment will enable the test start time to be defined manually at time in day when the timer was reset. It will also disable the adaptive test algorithm thereby forcing the unit to perform the test at the same time rather than it being defined by the adaptive algorithm. This function will only work provided the interval time is greater than zero (automatic test mode enabled). The delay timer value set when the unit was commissioned will be reloaded in order to randomise the tests between adjacent units.

#### Prolong time

Prolong time can be set by the DALI controller. This is the delay time between return of the mains supply and the end of the emergency operation. The default prolong time is set as 0 minutes as specified within the DALI standard.

Indicator LED will stay off for the duration of the prolong time.



**Rest Mode**

Rest mode can be initiated by the DALI controller. The appropriate command should be sent after the mains supply has been disconnected and whilst the module is in emergency operation. After a mains reset the EM R2A PRO exits the rest mode. EM R2A PRO supports the re-light command via the DALI bus.

Max. rest mode duration: 21 days from fully charged battery

**DALI Controller**

DALI controllers and hardware/software solutions are available from Tridonic. Please refer to the Lighting controls section.

**7.3 Technical data batteries**

**Accu Lithium Iron Phosphate**

Case temperature range

to ensure 8 years design life

1.5 / 3.0 Ah, insulated ceilings +5 °C to +35 °C

Case temperature range

to ensure 6 years design life

1.5 / 3.0 Ah, non-insulated ceilings +5 °C to +45 °C

International designation

IFpR 19/66

Battery voltage/cell

3.2 V

Single cell dimensions

Diameter 18 mm

Height 65 mm

Capacity one cell

1.5 Ah

Capacity two cell pack

3.0 Ah

Max. short term temperature (reduced lifetime)

55 °C

Max. number discharge cycles

50 cycles total

Packing quantity

1 pc. per carton

Comply with UN 38.3 and IEC 62133 (safety testing) protected against over charge, over discharge, charging at excessive temperatures, short-circuit and over current.

For battery data see separate data sheet.

**8. Optical properties**

**8.1 Anti panic**

**Max. spacing for >0.5 lux<sup>①</sup>**

Height	Centre to end <sup>②</sup>		Centre to centre <sup>③</sup>	
	Trans	Axial	Trans	Axial
2.5 m	3.85 m	3.80 m	10.90 m	10.85 m
3.0 m	3.80 m	3.75 m	11.90 m	11.90 m
3.5 m	3.80 m	3.80 m	12.90 m	12.90 m
4.0 m	3.70 m	3.70 m	13.90 m	13.85 m
5.0 m	3.55 m	3.50 m	14.90 m	14.90 m
6.0 m	3.10 m	3.05 m	15.10 m	15.05 m

All values for ta = 30 °C

Luminous flux. 200 lm

① Maintenance factor = 0.8, photometric data available on request

② Distance between module and wall

③ Distance between two modules

Light distribution

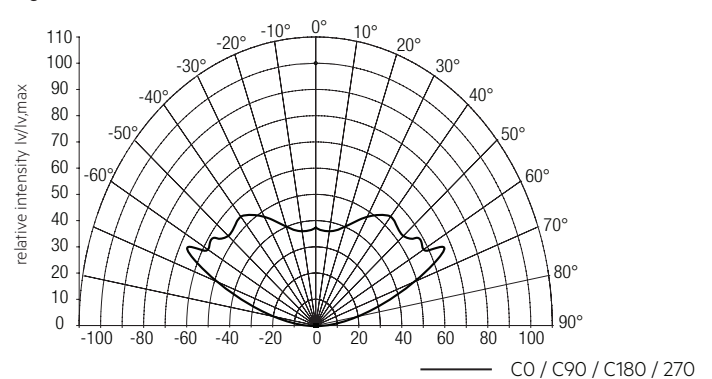

**8.2 Escape route**

**Max. spacing for >1.0 lux<sup>①</sup>**

Height	Centre to end <sup>②</sup>		Centre to centre <sup>③</sup>	
	Trans	Axial	Trans	Axial
2.5 m	4.75 m	2.75 m	11.65 m	6.55 m
3.0 m	4.80 m	2.95 m	12.75 m	7.20 m
3.5 m	5.05 m	1.50 m	13.45 m	6.85 m
4.0 m	5.20 m	1.65 m	13.60 m	6.50 m
5.0 m	5.50 m	1.80 m	14.30 m	4.35 m
6.0 m	5.70 m	1.90 m	15.05 m	4.85 m
7.0 m	5.75 m	1.90 m	15.60 m	5.15 m
8.0 m	5.65 m	1.85 m	16.05 m	5.35 m

All values for ta = 30 °C

Luminous flux: 200 lm

① Maintenance factor = 0.8, photometric data available on request

② Distance between module and wall

③ Distance between two modules

Light distribution

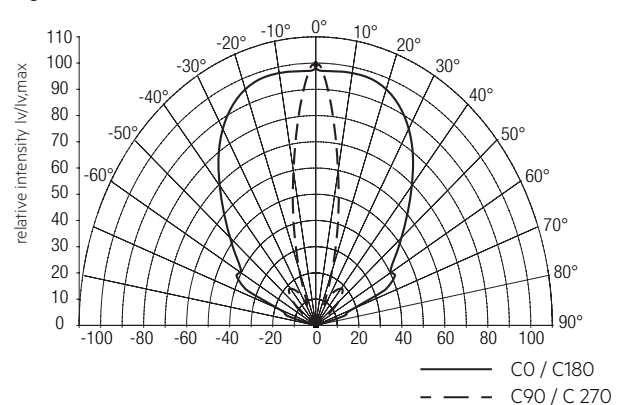

### 8.3 Spot

**Max. spacing for >0.5 lux / > 5 lux<sup>①</sup>**

Minimum illuminance	Height	Centre to end <sup>②</sup>		Centre to centre <sup>③</sup>	
		Trans	Axial	Trans	Axial
0.5	2.5 m	1.05 m	1.90 m	8.40 m	4.30 m
	3.0 m	2.35 m	1.25 m	5.35 m	5.20 m
	3.5 m	2.80 m	1.45 m	6.25 m	6.05 m
	4.0 m	1.70 m	1.70 m	7.90 m	5.85 m
	5.0 m	2.10 m	2.05 m	8.90 m	8.40 m
	6.0 m	2.30 m	2.30 m	8.15 m	8.10 m
	7.0 m	2.50 m	2.45 m	8.00 m	8.00 m
	8.0 m	2.65 m	2.60 m	7.80 m	7.85 m
5.0	2.5 m	0.85 m	0.80 m	2.50 m	2.45 m
	3.0 m	0.90 m	0.85 m	2.55 m	2.55 m
	3.5 m	0.90 m	0.90 m	2.75 m	2.75 m
	4.0 m	0.90 m	0.95 m	2.95 m	2.95 m
	5.0 m	0.95 m	0.90 m	3.30 m	3.25 m
	6.0 m	0.95 m	0.90 m	3.50 m	3.45 m
	7.0 m	0.85 m	0.85 m	3.60 m	3.55 m
	8.0 m	0.75 m	0.75 m	3.60 m	3.60 m

All values for  $t_a = 30^\circ\text{C}$

Luminous flux: 200 lm

<sup>①</sup> Maintenance factor = 0.8, photometric data available on request

<sup>②</sup> Distance between module and wall

<sup>③</sup> Distance between two modules

#### Light distribution

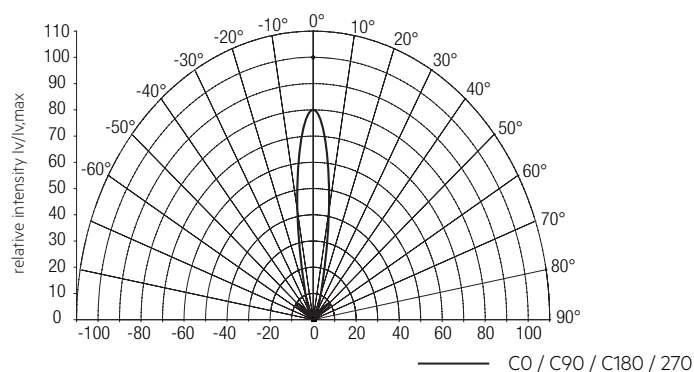

## 9. Miscellaneous

### 9.1 Black Box data recording

Recording of several parameters only accessible for Tridonic.

### 9.2 Additional information

Additional technical information at [www.tridonic.com](http://www.tridonic.com) → Technical Data

The light source of this luminaire is not replaceable; when the light source reaches its end of life replace the whole luminaire. Lifetime declarations are informative and represent no warranty claim. No warranty if device was opened.