

EM ready2apply PRO 2 W SM

EM ready2apply

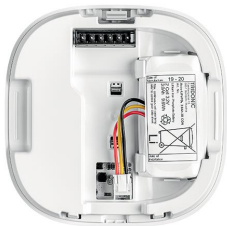

Product description

- _ LED emergency module suitable for surface mounted installation
- _ Complete set with integrated electronics, LED module, heat sink, optics and battery
- _ Includes click-in multi-lens option for anti-panic, escape route and spot illumination
- _ DALI interface and automatic test function
- _ BESA compatible mounting
- _ EM = Emergency

Properties

- _ Output power 1.5 W
- _ Very low stand-by power loss
- _ Non-maintained variants
- _ 1 or 3 h rated duration (separate variants)
- _ Simple connection of Lithium Iron Phosphate battery with plug-in system
- _ White or black housing colour options
- _ Back box in two different heights available (for rear and side entry)
- _ 5 years guarantee electronic (LED driver) (conditions at <https://www.tridonic.com/manufacture-guarantee-conditions>)
- _ 5 years guarantee for LiFePO4 batteries (conditions at <https://www.tridonic.com/manufacture-guarantee-conditions>)

Website

<http://www.tridonic.com/89800765>



EM ready2apply PRO 2 W SM

EM ready2apply

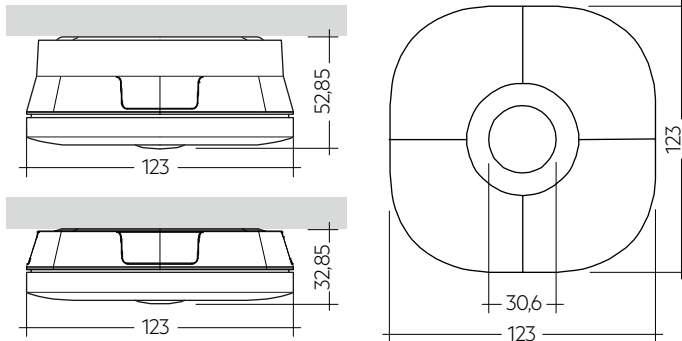

Ordering data

Type	Article number	Colour	Design	Rated duration	Number of cells	Packaging, carton	Packaging, pallet	Weight per pc.
EM R2A PRO 112 SM	89800765	White	low	1 h	2	1 pc(s).	400 pc(s).	0.27 kg
EM R2A PRO 132 SM	89800766	White	low	3 h	2	1 pc(s).	400 pc(s).	0.27 kg
EM R2A PRO 112 SMh	89800767	White	high	1 h	2	1 pc(s).	400 pc(s).	0.30 kg
EM R2A PRO 132 SMh	89800768	White	high	3 h	2	1 pc(s).	400 pc(s).	0.30 kg
EM R2A PRO 112 SM-B	89800820	Black	low	1 h	2	1 pc(s).	400 pc(s).	0.27 kg
EM R2A PRO 132 SM-B	89800821	Black	low	3 h	2	1 pc(s).	400 pc(s).	0.27 kg
EM R2A PRO 112 SMh-B	89800822	Black	high	1 h	2	1 pc(s).	400 pc(s).	0.30 kg
EM R2A PRO 132 SMh-B	89800823	Black	high	3 h	2	1 pc(s).	400 pc(s).	0.30 kg

Technical data

Rated supply voltage	220 – 240 V
Input voltage range AC (tolerance for safety)	198 – 264 V
Input voltage range AC (tolerance for performance)	198 – 254 V
Mains frequency	50 / 60 Hz
Overvoltage protection	320 V (for 48 h)
Starting time (Emergency operation)	< 0.5 s from detection of emergency event
Output current tolerance	± 5 %
LF current ripple	± 5 %
Ambient temperature t_a	5 ... 40 °C
Mains voltage changeover threshold	According to EN 60598-2-22
Type of protection	IP20
Impact protection rating [®]	IK07
Protection class	II
Colour temperature	6,500 K
Colour tolerance	3 SDCM
Colour rendering index CRI	> 80
Lifetime	up to 50,000 h

Approval marks



Standards

according to EN 50172, EN 55015, EN 60068-2-6, EN 60068-2-30, EN 60598-1, EN 60598-2-2, EN 60598-2-22, EN 61000-3-2, EN 61000-3-3, EN 61347-1, EN 61347-2-7, EN 61347-2-13, EN 61547, acc. to EN 62034, EN 62384, EN 62386-101, EN 62386-102, DALI standard EN 62386-202, IEC 62133 (related to Lithium Iron battery), UN 38.3 (related to Lithium Iron battery), EN 62031, EN 62471

Specific technical data

Type	Number of battery cells	Rated duration	Mains current (230 V, 50 Hz), non-maintained		Mains power (230 V, 50 Hz), non-maintained		Typ. λ (at 230 V, 50 Hz, charging)	Typ. output current	Typ. forward voltage	Output power
			Charging	Charger off	Charging	Charger off				
Normal operation										
EM R2A PRO 112 SM	2	1 h	20 mA	10 mA	2.5 W	0.6 W	0.5C	-	-	-
EM R2A PRO 132 SM	2	3 h	20 mA	10 mA	2.5 W	0.6 W	0.5C	-	-	-
EM R2A PRO 112 SMh	2	1 h	20 mA	10 mA	2.5 W	0.6 W	0.5C	-	-	-
EM R2A PRO 132 SMh	2	3 h	20 mA	10 mA	2.5 W	0.6 W	0.5C	-	-	-
EM R2A PRO 112 SM-B	2	1 h	20 mA	10 mA	2.5 W	0.6 W	0.5C	-	-	-
EM R2A PRO 132 SM-B	2	3 h	20 mA	10 mA	2.5 W	0.6 W	0.5C	-	-	-
EM R2A PRO 112 SMh-B	2	1 h	20 mA	10 mA	2.5 W	0.6 W	0.5C	-	-	-
EM R2A PRO 132 SMh-B	2	3 h	20 mA	10 mA	2.5 W	0.6 W	0.5C	-	-	-
Emergency operation										
EM R2A PRO 112 SM	2	1 h	-	-	-	-	-	126 mA	12 V	1.5 W
EM R2A PRO 132 SM	2	3 h	-	-	-	-	-	126 mA	12 V	1.5 W
EM R2A PRO 112 SMh	2	1 h	-	-	-	-	-	126 mA	12 V	1.5 W
EM R2A PRO 132 SMh	2	3 h	-	-	-	-	-	126 mA	12 V	1.5 W
EM R2A PRO 112 SM-B	2	1 h	-	-	-	-	-	126 mA	12 V	1.5 W
EM R2A PRO 132 SM-B	2	3 h	-	-	-	-	-	126 mA	12 V	1.5 W
EM R2A PRO 112 SMh-B	2	1 h	-	-	-	-	-	126 mA	12 V	1.5 W
EM R2A PRO 132 SMh-B	2	3 h	-	-	-	-	-	126 mA	12 V	1.5 W

① IK07 in case of fixing the front plate to the back box with a M3x10 self-tapping screw (not supplied). With clip fixing only IK03.

LiFePO4 Battery pack 3.0 – 6.0 Ah

Accessory



LiFeGuard

Product description

- _ High temperature LiFePO4 cells for use with EM ready2apply surface mounted emergency lighting units
- _ 6 year design life (up to 30 °C ambient temperature)
- _ 4 year design life (up to 40 °C ambient temperature)
- _ 5 years guarantee (conditions at <https://www.tridonic.com/manufacture-guarantee-conditions>)

Properties

- _ Certified quality manufacturer
- _ Charge efficiency > 90 %
- _ Low self discharge
- _ Simple connection with plug-in system
- _ Protection and monitoring circuit built into battery enclosure
- _ Deep discharge protection
- _ Suitable for emergency lighting equipment as per IEC 60598-2-22

Website

<http://www.tridonic.com/28003554>



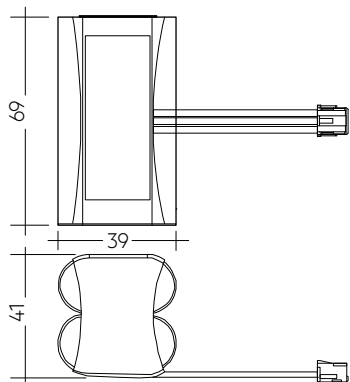
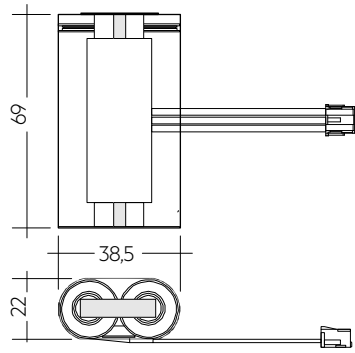

Ordering data

Type	Article number	Capacity	Packaging, carton	Weight per pc.
PACK-LiFePO4 3.0Ah 2A CON R2A SM	28003554	3 Ah	75 pc(s).	0.104 kg

1. Standards

according to EN 50172

EN 55015

EN 60068-2-6

according to EN 60068-2-30

EN 60598-1

EN 60598-2-2

EN 60598-2-22

EN 61000-3-2

EN 61000-3-3

EN 61347-1

EN 61347-2-7

EN 61347-2-7/A1

EN 61347-2-13

EN 61347-2-13/A1

EN 61547

according to EN 62034

EN 62384

EN 62386-101

EN 62386-102

EN 62386-202

IEC 62133 (related to Lithium Iron battery)

UN 38.3 (related to Lithium Iron battery)

EN 62031

EN 62471

1.1 Glow-wire test

according to EN 60598-1 with increased temperature of 850 °C passed.

2. Thermal data

2.1 Temperature range

According to the standard IEC 60598-1 a LED Driver for remote installation has a max. case temperature of 90 °C. The ambient temperature range t_a for the EM R2A PRO is defined to meet this requirement.

2.2 Expected lifetime

Average lifetime 50,000 hours under rated conditions with a failure rate of less than 10 %. Average failure rate of 0.2 % per 1000 operating hours.

Expected lifetime

Type	t_a	25 °C	35 °C	40 °C
EM R2A PRO	lifetime	> 100,000 h	> 50,000 h	50,000 h

2.3 Storage conditions

- Humidity 5 % up to max. 85 %, not condensed (max. 56 days/year at 85 %)

Note: The devices have to be within the specified temperature range (t_a) before they are operated.

- Store batteries within the specified temperature range in low humidity conditions. Optimal storage conditions are:
 - Temperature: -20 ... +25 °C for up to 12 months
 - 20 ... +35 °C for up to 6 months
 - Relative humidity: 65 % ± 5 %
- Avoid atmosphere with corrosive gas
- Disconnect batteries before store or delivery
- Avoid storage of discharged batteries

3. Installation / Wiring

3.1 Lens assembly

- Wear gloves when mounting the lens
- Take care of the mounting direction of the escape route lens
- Use screwdriver for replacing/removing lens
 - + 2. Push lens clips with screwdriver via openings on both sides
 3. Remove lens

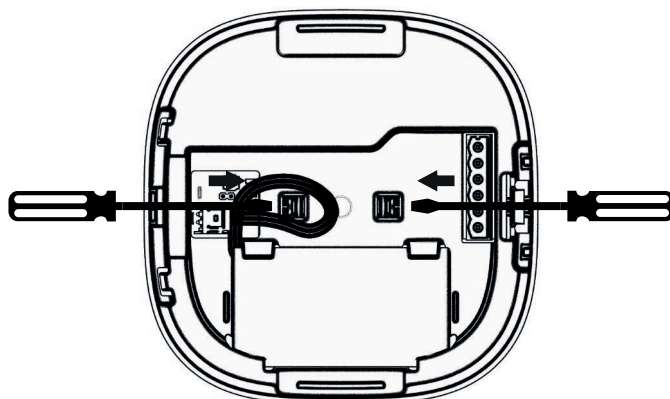

3.2 Luminaire assembly

- Back box preparation:
 - For rear entry: 2 drill locations are provided for a 20 mm hole
 - For side entry (use of deep back box): 3 locations are provided for use with 20 mm cable glands.
- If required use a M3x10 self tapping screw (not supplied) to secure the front plate to the back box. Drill a 3 mm hole in the back box indent.
- Fix the back box to the ceiling (BESA compatible mounting). Note: direction arrows allowing correct orientation for corridor lens.
- Change lenses if required (pre-fitted with anti panic lens).
- Wiring of the mains terminal block will require a suitable tool to open the cage clamp (size 3.5 x 0.5 mm blade).
- Plug battery into connector.
- Fix front plate to back box: locating battery side tabs first, push home, a click will be heard when front plate is inserted correctly.
- Apply power and the green charge indicator LED will be illuminated.
- The deep back box has a parking facility for up to 6 Wago 2773 series connectors (not supplied) to aid through wiring cable management.



Take care when drilling to prevent damage to internal components.

If an impact protecting rating of above IK03 to a max. of IK07 is required, use an M3x10 self-tapping screw for the assembly.

3.3 Wiring diagrams

3.3.1 Wired set-up

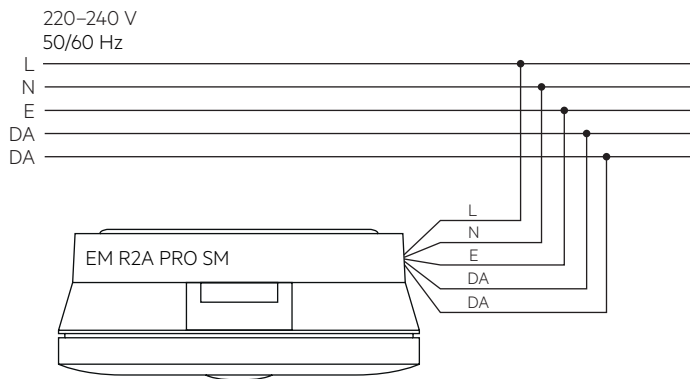

Note: Battery must be connected before mains connection.

3.3.2 Wireless set-up

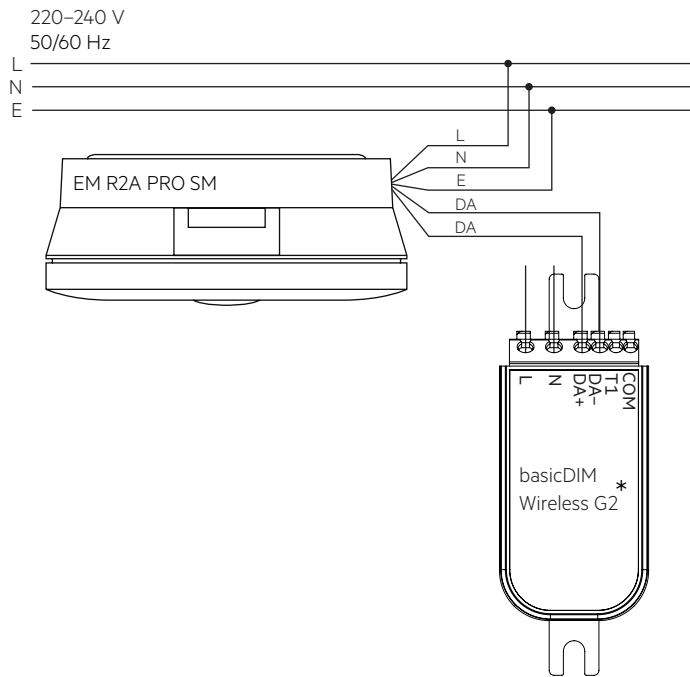

Note: Battery must be connected before mains connection.

* For further information see basicDIM Wireless datasheet at www.tridonic.com

3.4 Wiring type and cross-section

Wiring

Mains (N, L): blue, brown

Earth terminal (E)

DALI (DA1, DA2): orange, orange

Cable: low smoke, halogen free

wire preparation:

0.5 – 2.5 mm²

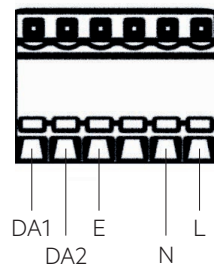
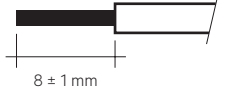

The installation of the luminaire has to be done by a qualified person.

3.5 Earth terminal (E)

The earth terminal is a loose connection without function. Use it to connect the earth wire to prevent it being loose in the luminaire. There is no earth connection required for the functionality of the EM ready2apply.

4. Mechanical data

4.1 Housing properties

- Polycarbonate white RAL 9016
- Polycarbonate black RAL 9005

4.2 Battery connection

Battery pack connection
3-pole plug connection

4.3 Fixing

Surface Mount with options for cable entry by BESA, rear and side entry. To minimise dust ingress used cable entry holes will be drill out. Screw holes for BESA and general mounting are oval shape to allow adjustment and are pre-drilled to simplify the final installation.

5. Electrical data

5.1 Maximum loading of automatic circuit breakers

Automatic circuit breaker type	C10	C13	C16	C20	B10	B13	B16	B20	Inrush current
Installation Ø	1.5 mm ²	1.5 mm ²	2.5 mm ²	4 mm ²	1.5 mm ²	1.5 mm ²	2.5 mm ²	4 mm ²	I _{max} time
EM R2A PRO	180	260	260	260	90	130	130	130	10 A 120 µs

5.2 Insulation matrix

	Mains	Battery	DALI
Mains	–	••	•
Battery	••	–	•
DALI	•	•	–

- Represents basic insulation
- Represents double or reinforced insulation

DALI terminals are not SELV. Wire the terminals in accordance with the requirements of low voltage installations.

5.4 Battery charge regime / discharge

EM R2A PRO 2 W SM, 1 / 3 h

	Type	EM R2A PRO 2 W SM
	Article no.	89800765-68 / 89800820-23
	Cells	2 cells
	Duration	1 / 3 h
Battery charge time	Initial	20 h
	Recharge	12 h
	Trickle charge	continuously and battery voltage controlled
Typ. charge current ^①	Initial charge	290 mA
	Recharge	290 mA
	Trickle charge	290 mA / 0 mA
Discharge current at 3.2 V (nominal)		625 mA

^① Automatic recharge when battery voltage falls below 3.4 V. Charger off (0 mA) when battery voltage exceeds 3.6 V.

Note: Battery protected against operation at excessive temperatures (charging stopped when battery cell temperature < 0 °C or > 60 °C)

5.5 Battery selection for replacement

EM R2A PRO 2 W SM, 1 / 3 h

			Type	EM R2A PRO 2 W SM	
			Article no.	89800765-68 / 89800820-23	
			Cells	2 cells	
			Duration	1 / 3 h	
Technology and capacity	Design	Number of cells	Type	Article no.	Assignable batteries
Lithium Iron Phosphate 3 Ah	side by side	1 + 1	EM R2A SM ACCU-LiFePO4 3.0Ah 2A CON	28003554	•

Note: If the rated duration of operation cannot be reached the battery must be replaced. Remove mains during battery replacement.

6. Interfaces / communication

6.1 Control input (DALI DT1)

The control input is non-polar for digital control signals (DALI). The control signal is not SELV. Control cable has to be installed in accordance to the requirements of low voltage installations.

7. Functions

7.1 Status indication

System status is indicated by a bi-colour LED and by a DALI status flag. The indication LED is integrated in the bezel.

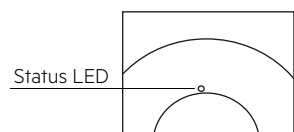

LED indication	Status	Comment
Permanent green	System OK	AC mode
Fast flashing green (0,1 sec on – 0,1 sec off)	Function test underway	
Slow flashing green (1 sec on – 1 sec off)	Duration test underway	
Red LED on	Load failure	Open circuit / Short circuit / LED failure
Slow flashing red (1 sec on – 1 sec off)	Battery failure	Battery failed the duration test or function test / Battery is defect or deep discharged / Incorrect battery voltage / Battery is outside of its temperature range for charging (0 – 60 °C)
Fast flashing red (0,1 sec on – 0,1 sec off)	Charging failure	Incorrect charging current
Double pulsing green	DALI Inhibit	Switching into DALI inhibit mode via controller
Binary transmission of address via green/red LED	Address identification	During address identification mode
Green and red off	DC mode	Battery operation (emergency mode)

7.2 Testing

Emergency operation can be manually tested by removal of the mains supply.

DALI Control

A DALI command from a suitable control unit can be used to initiate function and duration tests at individually selected times. Status flags are set for report back and data logging of results.

When a DALI bus has not been connected or when a DALI bus is connected but the DALI default DELAY and INTERVAL times have not been re-set by sending appropriate DALI commands, then the EM R2A PRO will conduct self-tests in accordance with the default times set within the EEPROM.

These default times are factory pre-set, in accordance with the DALI standard EN 62386-202, to conduct an automatic function test every 7 days and a duration test every 52 weeks. Since the DELAY time is factory pre-set to Zero, all units are tested at the same time. Test times can be changed with a command over the DALI bus.

The DELAY and INTERVAL time values must be re-set when the emergency system test times are to be scheduled by a DALI control and monitoring system.

Note that once the default values have been set to Zero, tests will only be conducted following a command from the control system. If the DALI bus is disconnected the EM R2A PRO does not revert to self-testing mode.

Note: If the battery is connected the DALI communication is only possible after power reset.

Addressing

The EM R2A PRO includes the EZ easy addressing system which allows addressing and identification by using the bi-colour LED. Binary address codes given by the LED can be simply converted to the DALI addresses 0 to 63. For single handed addressing using this method it is necessary to send a broadcast ident command every 3 to 9 seconds. During this command the LEDs will be switched off and the indication LED will flash the 6 bit binary address preceded by a 3 second start indication period.

Commissioning

After installation of the luminaire and initial connection of the mains supply and battery supply to the EM R2A PRO the unit will commence charging the batteries for 20 hours (initial charge). Afterwards the module will conduct a commissioning test for the full duration. The 20 hours recharge occurs also if a new battery is connected or the module exits the rest mode condition. The following automatic commissioning duration test is only performed when a battery is replaced and fully charged (after 20 hrs) and the interval time is not set to zero, otherwise the system is expected to perform the testing.

Functional test

The time of day and frequency of the 5 seconds function test can be set by the DALI controller. The default setting is a 5 seconds test on a weekly basis.

Duration test

The time of day and frequency of the duration test can be set by the DALI controller. The default setting is a duration test conducted every 52 weeks.

Timer reset functionality

The timer for function and duration test can be set to a particular time of the day by cycling the unswitched line supply 5 times within 1 minute. The timer adjustment will enable the test start time to be defined manually at time in day when the timer was reset. It will also disable the adaptive test algorithm thereby forcing the unit to perform the test at the same time rather than it being defined by the adaptive algorithm. This function will only work provided the interval time is greater than zero (automatic test mode enabled). The delay timer value set when the unit was commissioned will be reloaded in order to randomise the tests between adjacent units.

Prolong time

Prolong time can be set by the DALI controller. This is the delay time between return of the mains supply and the end of the emergency operation. The default prolong time is set as 0 minutes as specified within the DALI standard.

Indicator LED will stay off for the duration of the prolong time.

Rest Mode

Rest mode can be initiated by the DALI controller. The appropriate command should be sent after the mains supply has been disconnected and whilst the module is in emergency operation. After a mains reset the EM R2A PRO exits the rest mode. EM R2A PRO supports the re-light command via the DALI bus.

Max. rest mode duration: 21 days from fully charged battery

DALI Controller

DALI controllers and hardware/software solutions are available from Tridonic. Please refer to the Lighting controls section.

7.3 Technical data batteries

Accu Lithium Iron Phosphate

International designation	IFpR 19/66
Battery voltage/cell	3.2 V
Single cell dimensions	
Diameter	18 mm
Height	65 mm
Capacity two cell pack	3.0 Ah
Max. short term temperature (reduced lifetime)	70 °C
Max. number discharge cycles	50 cycles total
Packing quantity	1 pc. per carton

Comply with UN 38.3 and IEC 62133 (safety testing) protected against over charge, over discharge, charging at excessive temperatures, short-circuit and over current.

For battery data see separate data sheet.

8. Optical properties

8.1 Anti panic

Max. spacing for >0.5 lux^①

Height	Centre to end ^②		Centre to centre ^③	
	Trans	Axial	Trans	Axial
2.5 m	3.85 m	3.80 m	10.90 m	10.85 m
3.0 m	3.80 m	3.75 m	11.90 m	11.90 m
3.5 m	3.80 m	3.80 m	12.90 m	12.90 m
4.0 m	3.70 m	3.70 m	13.90 m	13.85 m
5.0 m	3.55 m	3.50 m	14.90 m	14.90 m
6.0 m	3.10 m	3.05 m	15.10 m	15.05 m

All values for ta = 30 °C

Luminous flux: 200 lm

① Maintenance factor = 0.8, photometric data available on request

② Distance between module and wall

③ Distance between two modules

Light distribution

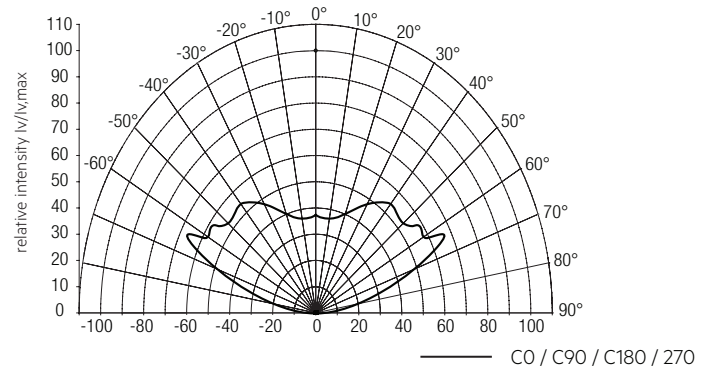

8.2 Escape route

Max. spacing for >1.0 lux^①

Height	Centre to end ^②		Centre to centre ^③	
	Trans	Axial	Trans	Axial
2.5 m	4.75 m	2.75 m	11.65 m	6.55 m
3.0 m	4.80 m	2.95 m	12.75 m	7.20 m
3.5 m	5.05 m	1.50 m	13.45 m	6.85 m
4.0 m	5.20 m	1.65 m	13.60 m	6.50 m
5.0 m	5.50 m	1.80 m	14.30 m	4.35 m
6.0 m	5.70 m	1.90 m	15.05 m	4.85 m
7.0 m	5.75 m	1.90 m	15.60 m	5.15 m
8.0 m	5.65 m	1.85 m	16.05 m	5.35 m

All values for ta = 30 °C

Luminous flux: 200 lm

① Maintenance factor = 0.8, photometric data available on request

② Distance between module and wall

③ Distance between two modules

Light distribution

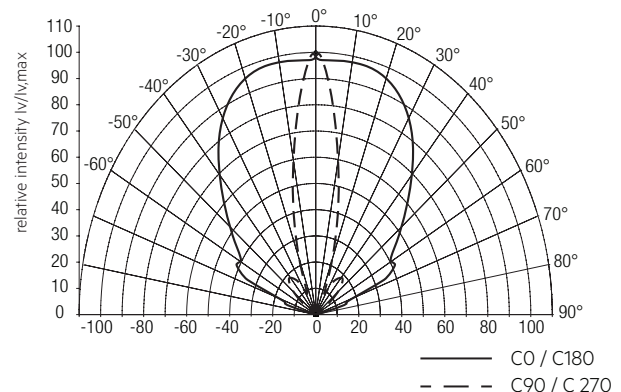

8.3 Spot

Max. spacing for >0.5 lux / > 5 lux^①

Minimum illuminance	Height	Centre to end ^②		Centre to centre ^③	
		Trans	Axial	Trans	Axial
0.5	2.5 m	1.05 m	1.90 m	8.40 m	4.30 m
	3.0 m	2.35 m	1.25 m	5.35 m	5.20 m
	3.5 m	2.80 m	1.45 m	6.25 m	6.05 m
	4.0 m	1.70 m	1.70 m	7.90 m	5.85 m
	5.0 m	2.10 m	2.05 m	8.90 m	8.40 m
	6.0 m	2.30 m	2.30 m	8.15 m	8.10 m
	7.0 m	2.50 m	2.45 m	8.00 m	8.00 m
	8.0 m	2.65 m	2.60 m	7.80 m	7.85 m
5.0	2.5 m	0.85 m	0.80 m	2.50 m	2.45 m
	3.0 m	0.90 m	0.85 m	2.55 m	2.55 m
	3.5 m	0.90 m	0.90 m	2.75 m	2.75 m
	4.0 m	0.90 m	0.95 m	2.95 m	2.95 m
	5.0 m	0.95 m	0.90 m	3.30 m	3.25 m
	6.0 m	0.95 m	0.90 m	3.50 m	3.45 m
	7.0 m	0.85 m	0.85 m	3.60 m	3.55 m
	8.0 m	0.75 m	0.75 m	3.60 m	3.60 m

All values for $t_a = 30^\circ\text{C}$

Luminous flux: 200 lm

^① Maintenance factor = 0.8, photometric data available on request

^② Distance between module and wall

^③ Distance between two modules

Light distribution

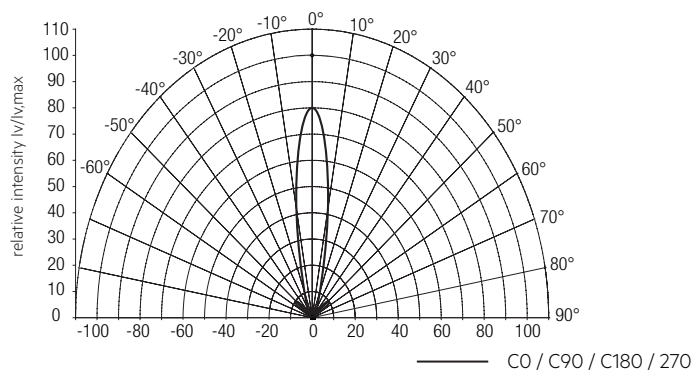

9. Miscellaneous

9.1 Battery replacement

After a battery replacement and a subsequent full charge cycle (24 h) a duration test is mandatory to prove that with the new battery the rated duration is achieved.



Do not damage battery and other components during battery replacement.

9.2 Black Box data recording

Recording of several parameters only accessible for Tridonic.

9.3 Additional information

Additional technical information at www.tridonic.com → Technical Data

The light source of this luminaire is not replaceable; when the light source reaches its end of life replace the whole luminaire. Lifetime declarations are informative and represent no warranty claim. No warranty if device was opened.