

DALI RM CDM 30 10A 1CH

DALI-2 single channel relay

**Product description**

- _ DALI-2 Relay
- _ Compatible with DALI and DALI-2 versions
- _ Compliant to IEC 62386-208
- _ 1 channel actuator (switch) with DALI-2 input
- _ Protected against DALI over voltage
- _ Suitable for switchboard mount on standard DIN rail
- _ Mains rated dry-contact (volt-free) potential free relay output
- _ Compliant DALI device type 7
- _ Small dimensions
- _ 5 years guarantee (conditions at <https://www.tridonic.com/manufacture-guarantee-conditions>)

Interfaces

- _ DALI

Functions

- _ Optimized for electronic loads with high in-rush currents like LED drivers, which have short but very high peaks of in-rush currents
- _ Switching of loads with inrush currents up to 490 A / 1.5 ms
- _ Compliant with common DALI-2 controllers and gateways
- _ DALI backwards compatible

Website

<http://www.tridonic.com/28003311>



DALI RM CDM 30 10A 1CH

DALI-2 single channel relay

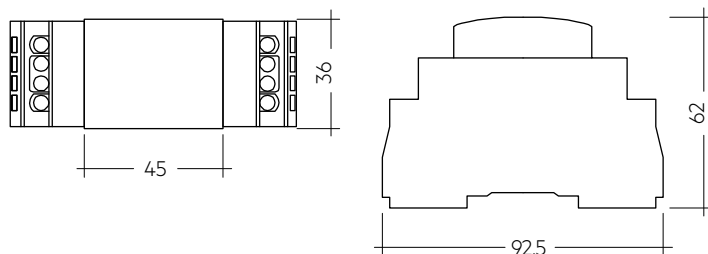
**Ordering data**

Type	Article number	Packaging, carton	Weight per pc.
DALI RM CDM 30 10A 1CH	28003311	40 pc(s).	0.088 kg

Technical data

Rated supply voltage	220 – 240 V
Mains frequency	50 / 60 Hz
Current consumption of DALI	2 mA
Input	DALI
Output	Potential free contact
Relay type	non-latching, normally open
Output load (resistive / inductive)	10 A / 6 A
In-rush current (peak / duration)	490 A / 1,500 µs
Relay switching cycles ^①	50,000
Ambient temperature t_a	-20 ... +45 °C
Storage temperature t_s	-20 ... +65 °C
Humidity	20 ... 90 % (non-condensing)
Starting time	≤ 0.3 s
Type of protection	IP20
Protection class	Protection class II
Mounting	DIN rail mounting, 35 mm
Housing material	Polycarbonate
Housing colour	White (RAL 9003)
Guarantee (conditions at www.tridonic.com)	5 Year(s)
Dimensions L x W x H	92.5 x 36 x 62 mm

Approval marks**Standards**

EN 55015, EN 60669-2-1, EN 61000-3-2, EN 61000-3-3, EN 62386-208, EN 62386-101, EN 62386-102

^① Max. switch cycles per hour are 360. One cycle is either close or open.

1. Standards

EN 55015
EN 60669-2-1
EN 61000-3-2
EN 61000-3-3
EN 62386-208
EN 62386-101 Ed.2
EN 62386-102 Ed.2

1.2 Glow wire test

according to EN 61347-2-11 passed for temperatures up to 750°C.

2. Common

- Loads that do not have a DALI input can be integrated in the DALI circuit. The loads can be switched on and off via DALI.

3. Installation

3.1 Safety instructions

- Do not connect the device to DC (direct current) voltage, as this will damage the device.
- Do not create a short circuit on the secondary side, as this will damage the device.
It is recommended to connect the device with a residual current circuit breaker (RCD) or a circuit breaker with a rated value not higher than 10 A to the secondary side to protect the device in case of a short circuit.
- Installation of this device may only be carried out by specialist staff who have provided proof of their skills.
- The power supply must be switched off before handling the device.
- The relevant safety and accident prevention regulations must be observed.
- DALI signals are not SELV. Therefore the same procedures should be applied as working with mains voltage.

3.2 Area of application

The device may only:

- be used for the applications specified,
- for safe installation in dry, clean environment and
- be installed in such a way that access is only possible using a tool.

3.3 Connection diagrams

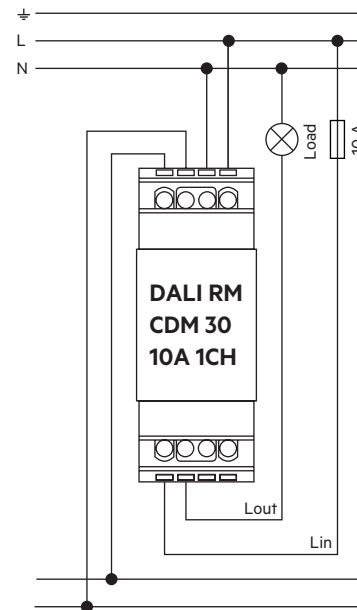
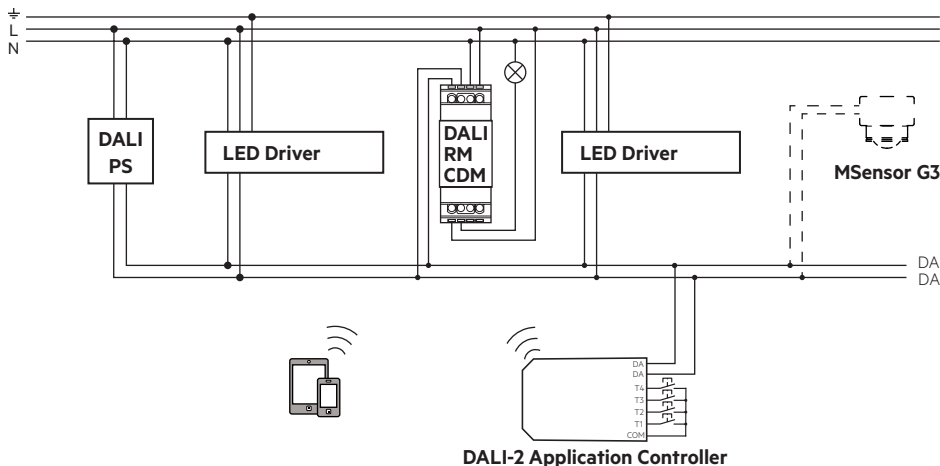

3.4 Installation

Mount the DALI relay on DIN rail inside a mains rated enclosure as shown in fig. 1.

To remove from DIN rail, release the clip mechanism with a flat blade screw driver, as per fig. 2.

Fig. 1

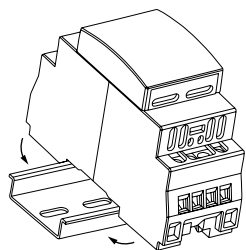
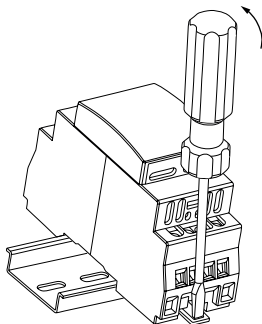
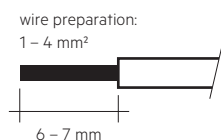

Fig. 2



3.5 Wiring type and cross section

The wiring can be solid wire or stranded wire with end sleeve with a cross-section of 1 to 4 mm².



3.6 Note for Application Controller

Device is developed according DALI Standard EN 62386-208 and is DALI device Type 7, control gear – Switching function.

4. Miscellaneous

4.1 Disposal of equipment



Return old devices in accordance with the WEEE directive to suitable recycling facilities.

4.2 Additional information

Additional technical information at www.tridonic.com → Technical Data

Lifetime declarations are informative and represent no warranty claim. No warranty if device was opened.