

**MSensor G3 PIR 4DPI WDA WH**

DALI-2 multi-sensor



MSensor G3 SFI 30 PIR 4DPI WDA WH



MSensor G3 SSM 30 PIR 4DPI WDA WH



MSensor G3 SRC 30 PIR 4DPI WDA WH

**Product description**

- \_ Sensor developed to work with the latest DALI specification
- \_ Wide detection angle of up to 125° covering an area of up to 141 m<sup>2</sup>
- \_ Monitoring of ambient light and occupancy detection
- \_ Remote control interface allowing infrared remote control interaction
- \_ Individual adjustment of the parameters with configuration software
- \_ Power supply via DALI line
- \_ Wide range of accessories allowing extended application range
- \_ Small dimensions allowing easy and inconspicuous integration in luminaries
- \_ 5 years guarantee (conditions at <https://www.tridonic.com/manufacture-guarantee-conditions>)

**Housing properties**

- \_ Casing: polycarbonate, white
- \_ Type of protection up to IP54

**Note**

- \_ Tridonic MSensor G3 family sensors are developed according to DALI Standard EN 62386-101 Ed.2, also known as DALI-2. To be able to use the sensor in such installation, an application controller is necessary.
- \_ List of approved application controller can be found on our WEB page in "Downloads" in document "Application\_controllers\_MSensor\_G3.pdf".

**Website**

<http://www.tridonic.com/28003808>



**MSensor G3 PIR 4DPI WDA WH**

DALI-2 multi-sensor

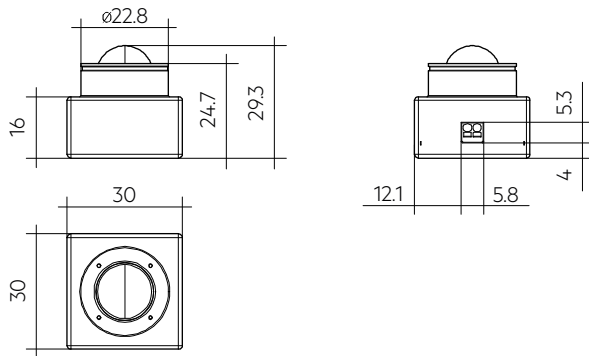

MSensor G3 SFI 30 PIR 4DPI WDA WH

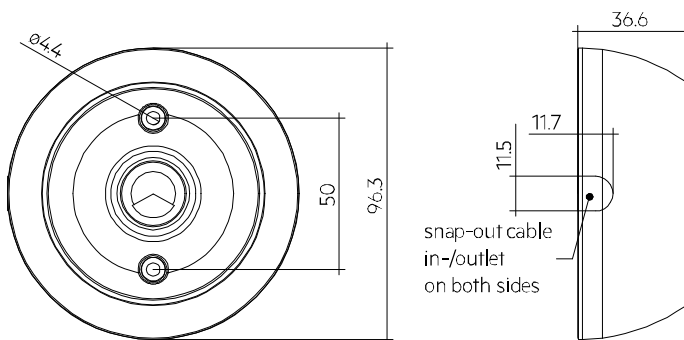

MSensor G3 SSM 30 PIR 4DPI WDA WH

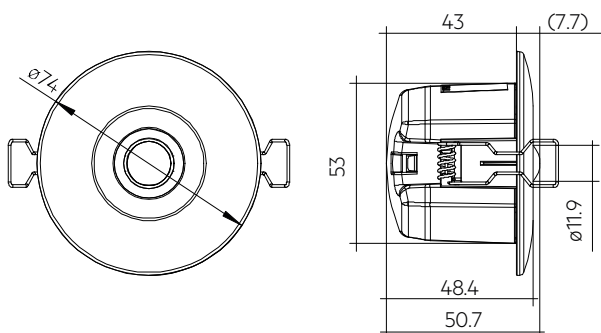

MSensor G3 SRC 30 PIR 4DPI WDA WH

**Ordering data**

Type	Article number	Dimensions L x W x H	Packaging, carton	Weight per pc.
MSensor G3 SFI 30 PIR 4DPI WDA WH	28003808	30.0 x 30.0 x 29.3 mm	10 pc(s).	0.013 kg
MSensor G3 SSM 30 4DPI WDA WH	28004637	96.3 x 96.3 x 36.6 mm	30 pc(s).	0.060 kg
MSensor G3 SRC 30 4DPI WDA WH	28004638	52.3 x 54.7 x 51.5 mm	10 pc(s).	0.058 kg

**Technical data**

Supply via	DALI cable
Supply voltage <sup>①</sup>	9.5 – 22.5 V
Current consumption (no LED)	max. 8 mA
Current consumption (with LED)	max. 9 mA
Starting time <sup>②</sup>	≤ 30 s
Supported operating modes	0 or 128 (default)
Mounting height	2 – 4 m
Mounting hole diameter	23 mm
Housing thickness of the luminaire	0.75 – 4 mm
Detection angle for PIR detection <sup>③</sup>	125°
Detection angle for light measurement <sup>④</sup>	80° – 150°
Detection range for light measurement <sup>⑤</sup>	0.5 – 2,000 lx
Min. temperature difference between ambient temperature and detected object	± 4 °C
Ambient temperature $t_a$	-20 ... +50 °C
$t_c$ point	60 °C
Storage temperature $t_s$	-25 ... +60 °C
Housing material body	PC polycarbonate
Housing material lens	PE polyethylene
Housing colour body	White (similar to RAL 9010)
Housing colour lens	White
Type of installation	Luminaire installation
Type of protection <sup>⑥</sup>	Up to IP54
Guarantee (conditions at <a href="http://www.tridonic.com">www.tridonic.com</a> )	5 Year(s)

**Approval marks****Standards**

EN 61347-2-11, IEC 61347-2-11, EN 55015, EN 61547, EN 62386-101, EN 62386-103, EN 62386-301, EN 62386-303, EN 62386-304

①  $U_{in}$  acc. IEC 62386-101.

② Starting time is the time until the PIR element of the sensor is ready and delivers correct values.

③ For details see chapter detection area in data sheet.

④ For details see chapter light measurement in data sheet.

⑤ The measured value at the sensor head corresponds to approx. 3 to 6,300 lux on the surface measured.

⑥ Depending on the installation type up to IP54 for more details see chapter 3.7.

Sensor mounting kit ACU 033 IP66 WH

Accessory



Product description

- \_ Easy to mount circlip locking, compatible with industry standard circlip pliers (size 19 – 60 mm)
- \_ Corrosion resistant circlip made from stainless steel
- \_ Appealing plastic cover ring, allowing to mount the sensor in luminaires in an easy and visual attractive way
- \_ Fulfills the impact energy requirements of freestanding luminaires of 0.5 J
- \_ Includes 2 gaskets offering flexible installation in luminaires
- \_ Plastic cover passed glow wire test with 750 °C in according to EN 61347-1
- \_ In combination with the MSensor G3 SFI 30 PIR 4DPI WDA WH, a maximum of IP54 is possible
- \_ In combination with the basicDIM ILD G2 4DPI WDA, a maximum of IP54 is possible

Website

<http://www.tridonic.com/28004207>



Ordering data

Type	Article number	Packaging, carton	Weight per pc.
Sensor mounting kit ACU 033 IP66 WH	28004207	20 pc(s).	0.006 kg

Sensor mounting kit ACU 030 IP66 WH

Accessory



Product description

- \_ Mounting ring allowing to mount the sensor into a luminaire in easy and visual attractive way
- \_ Including three different gaskets 3, 5 and 8 mm
- \_ For more details see data sheet chapter 3.5 (mounting ring) and 3.6 (gasket)
- \_ Mounting ring passed glow wire test with 750 °C according to EN 61347-1
- \_ In combination with the MSensor G3 SFI 30 PIR 4DPI WDA WH, a maximum of IP54 is possible

Website

<http://www.tridonic.com/28002459>



Ordering data

Type	Article number	Packaging, carton	Weight per pc.
Sensor mounting kit ACU 030 IP66 WH	28002459	20 pc(s).	0.006 kg

REMOTECONTROL IR6

Accessory



Product description

- \_ Optional infra-red remote control
- \_ Switching on and off (On/Off button)
- \_ Dimming (Up/Down button)
- \_ Activation of automatic lighting control (Automatic button)
- \_ Setting the threshold control point (Set button)
- \_ IR range up to 20 m

Website

<http://www.tridonic.com/28000647>



Ordering data

Type	Article number	Dimensions L x W x H	Packaging, carton	Weight per pc.
REMOTECONTROL IR6	28000647	86.5 x 40.5 x 7.2 mm	500 pc(s).	0.019 kg

Sensor housing ACU 031 IP20 WH

Accessory



Product description

- \_ Mounting frame for wired MSensor G3 SFI 30 PIR 10DPI WH sensors allowing direct mounting to the ceiling
- \_ Easy „click in“ installation of the sensor
- \_ IP20
- \_ Casing: polycarbonate, white
- \_ UV stabilized plastic
- \_ MSensor G3 SFI 30 PIR 10DPI WH is powered via DALI circuit
- \_ Mounting kit with screws and decorative plugs
- \_ 0.5 mm<sup>2</sup> wiring for the sensor
- \_ Two 3 x 1.5 mm<sup>2</sup> clamps with cable management (2 entry points on opposite sides)
- \_ Including gasket for ideal IP protection
- \_ Casing passed glow wire test with 850 °C according to EN 61347-1

Website

<http://www.tridonic.com/28001874>



MSensor G3 SSM 30 10DPI WH

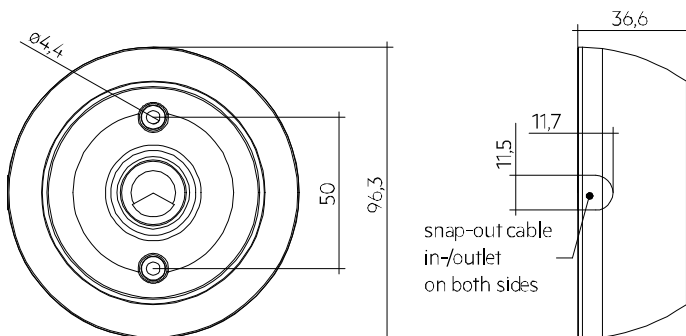

**Ordering data**

Type	Article number	Packaging, carton	Weight per pc.
Sensor housing ACU 031 IP20 WH	28001874	81 pc(s).	0.054 kg

**Sensor housing ACU 032 IP66 WH**

Accessory



**Product description**

- \_ Mounting frame for wired MSensor G3 SFI 30 PIR 10DPI WH sensors allowing direct mounting to the ceiling
- \_ Easy „click in“ installation of the sensor
- \_ Housing provides IP 66, but in combination with the MSensor G3 SFI 30 PIR 4DPI WDA WH a maximum of IP54 is possible
- \_ Casing: polycarbonate, white
- \_ UV stabilized plastic
- \_ MSensor G3 SFI 30 PIR 10DPI WH is powered via DALI circuit
- \_ Optional shutter for reduction of occupancy detection area allowing to decrease the occupancy detection area from 360° to 240°
- \_ Mounting kit with screws and decorative plugs
- \_ Including gasket for ideal IP protection
- \_ Casing passed glow wire test with 850 °C according to EN 61347-1

**Website**

<http://www.tridonic.com/28001873>

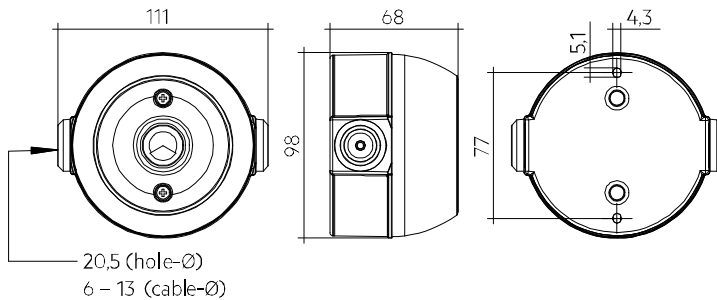

**Ordering data**

Type	Article number	Packaging, carton	Weight per pc.
Sensor housing ACU 032 IP66 WH	28001873	26 pc(s).	0.105 kg

Shading Set 4DPI WDA

Accessory

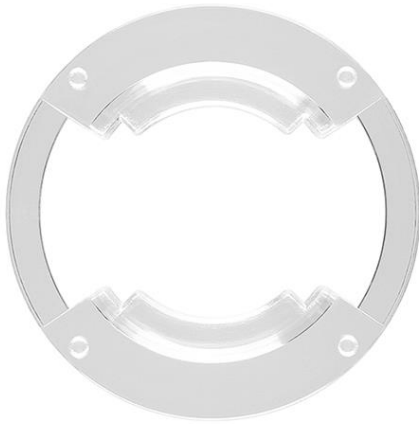

Corridor



90° shutter



180° shutter

**Product description**

- \_ Shading set consisting of 3 different types of lenses: Corridor, 90° and 180° shutter
- \_ Shutters mountable directly to the front of the sensor in 4 different positions 0°, 90°, 180° and 270° angle relative to the sensor device
- \_ No disturbance of light measurement or IR receiver signals
- \_ Material transparent Lexan 923 with polished surface finish
- \_ Shutters made for one time use, once installed removal may damage the shutter and sensor lens!

**Website**

<http://www.tridonic.com/28003867>



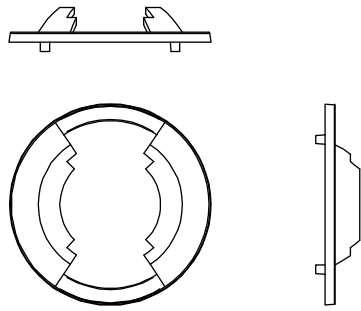

Corridor

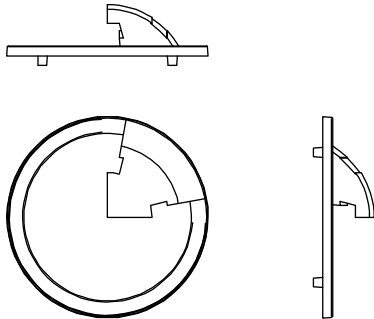

90° shutter

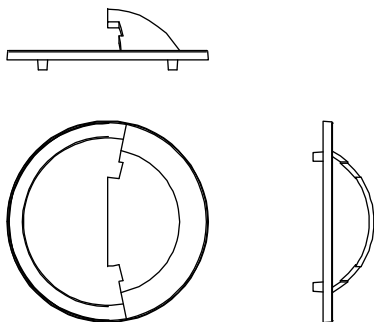

180° shutter

**Ordering data**

Type	Article number	Packaging, carton	Weight per pc.
ACU SHADING SET 034 4DPI WDA	28003867	20 pc(s).	0.001 kg



## 1. Standards

EN 61347-2-11:2001 + A1:2017  
 IEC 61347-2-11:2001, AMD1:2017  
 EN IEC 55015:2019 + A11:2020  
 CISPR15  
 EN 61547:2009  
 EN 62386-101 Ed.2  
 EN 62386-103 Ed.1  
 EN 62386-301  
 EN 62386-303  
 EN 62386-304  
 EN 62386-351

### 1.1 DALI note



Sensor is only applicable for DALI-2 installations according to EN 62386-101 Ed.2.  
 List of approved application controller can be found on our WEB page „[Application controllers\\_MSensor\\_G3.pdf](#)“

Following table shows the instances and which values they provide.

DALI instances	
Instance number	Explanation
0	Occupancy sensor DALI Part 303
1	Light sensor DALI Part 304
2 – 19 <sup>①</sup>	Push button DALI Part 301

<sup>①</sup> Sensors produced before 25.07.23 do provide 13 instances and do not support Tridonic IR6+ remote control.

### 1.2 D4i note

D4i luminaire-mounted control devices (part 351) = Type B

### 1.3 Glow wire test

according to EN 61347-2-11 passed for temperatures up to 850°C.

## 2. Common

MSensor G3 SFI 30 PIR 4DPI WDA WH is one of the new generation of Tridonic sensors.

With this Sensor, the customer gets a small sized sensor for low height applications and a protection against environmental influence up to IP54.

This sensor provides measurement of ambient light, occupancy detection via PIR sensor and IR remote control input as well as a LED output for signalisation.

MSensor G3 SFI 30 PIR 4DPI WDA WH is created for following main applications:

Low height buildings such as

- Office applications
- Factory buildings
- Storage buildings and warehouses
- Corridors, passages and Garages

## 3. Installation

- The MSensor must not be connected to the mains. It is supplied directly via the DALI power supply.
- DALI is not SELV.  
The installation instructions for mains voltage therefore apply.
- Please ensure that the detection range of the sensor lies in the lighting area of the controlled luminaires.
- Please ensure that the detection ranges of the sensors do not overlap. This may have influence to the lighting control.
- When installed at a height other than the recommended installation height, the sensor might show different characteristics. When mounted at a higher level, its sensitivity is reduced. If mounted at a lower level, its range is reduced.
- Heaters, fans, printers and copiers located in the detection zone may cause incorrect occupancy detection.
- Avoid direct illumination of the light source on the sensor including housing.
- If shutters are used it is important to keep in mind that shutters are made for one time use, once installed removal may damage the shutter and sensor lens!
- Do not use aggressive detergents to clean the e.g. sensor lens. Always make sure that the used detergent does not harm the sensor materials.

3.1 Wiring

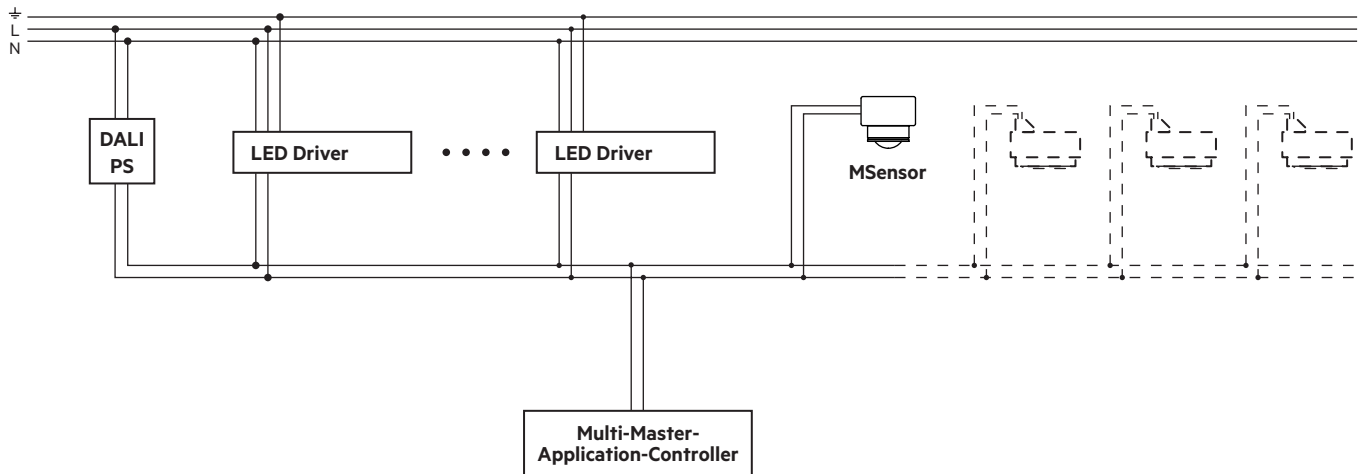

3.2 Wiring type and cross section

SFI version:

For wiring use stranded wire with ferrules from 0.2 to 0.5 mm<sup>2</sup> or solid wire from 0.14 to 0.5 mm<sup>2</sup>.

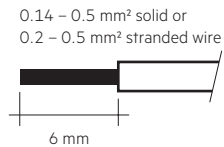

SRC version:

For wiring use stranded wire with ferrules or solid wire from 0.5–1.5 mm<sup>2</sup>. Strip 9 mm of insulation from the cables to ensure perfect operation of the push terminals. Use one wire for each terminal connector only. Use the strain relief for one cable only.

SSM version:

For wiring use solid wire from 0.5–1.5 mm<sup>2</sup>. Strip 9 mm of insulation from the cables to ensure perfect operation of the push terminals. Use one wire for each terminal connector only.

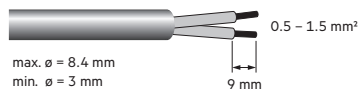

3.3 Mounting variants luminaire installation sensor:

3.3.1 Installation in luminaire

To ensure the right IP protection please read chapter 3.6 Gasket.

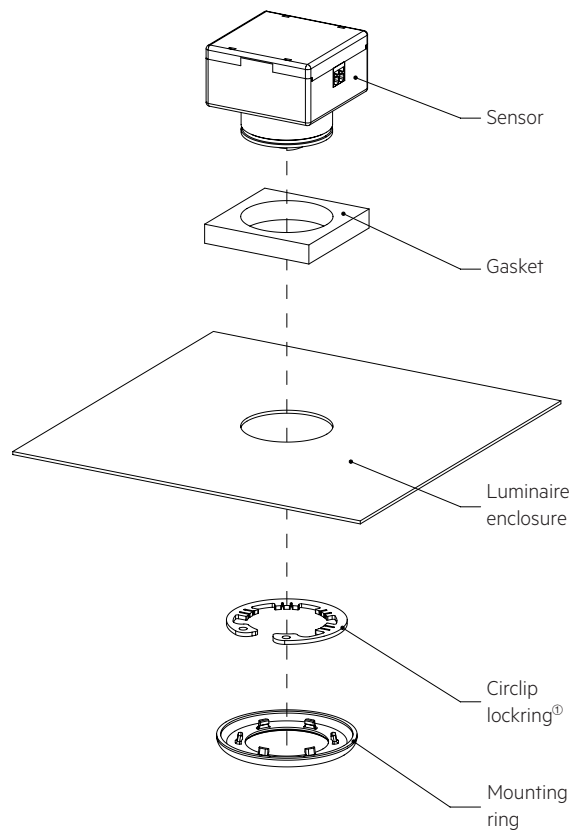

Ⓢ Not included in kit ACU 030.

3.3.2 Installation in Sensor housing ACU 032 IP66 WH

To ensure the right IP protection please read chapter 3.6 Gasket.

Step 1: Cover placed on base plate

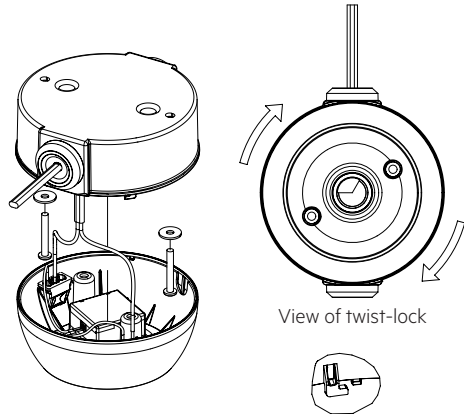

View of twist-lock

Step 2: Cover locked

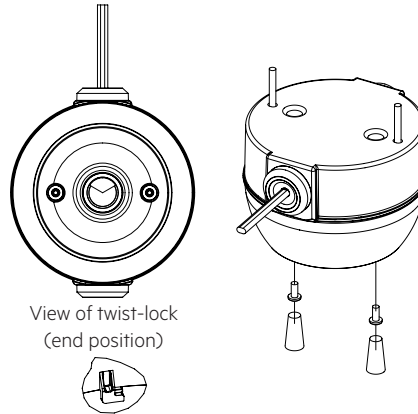

View of twist-lock  
(end position)

Mount base plate. Feed cable (cable diameter: 6 – 13 mm) of the lateral grommets into the installation terminals.

After the cover is loosely mounted on the base plate, insert and tighten the 2 screws. In the last step insert in the sealing plugs.

3.3.3 Installation in Sensor housing ACU 031 IP20 WH

To ensure the right IP protection please read chapter 3.6 Gasket.

Exploded view

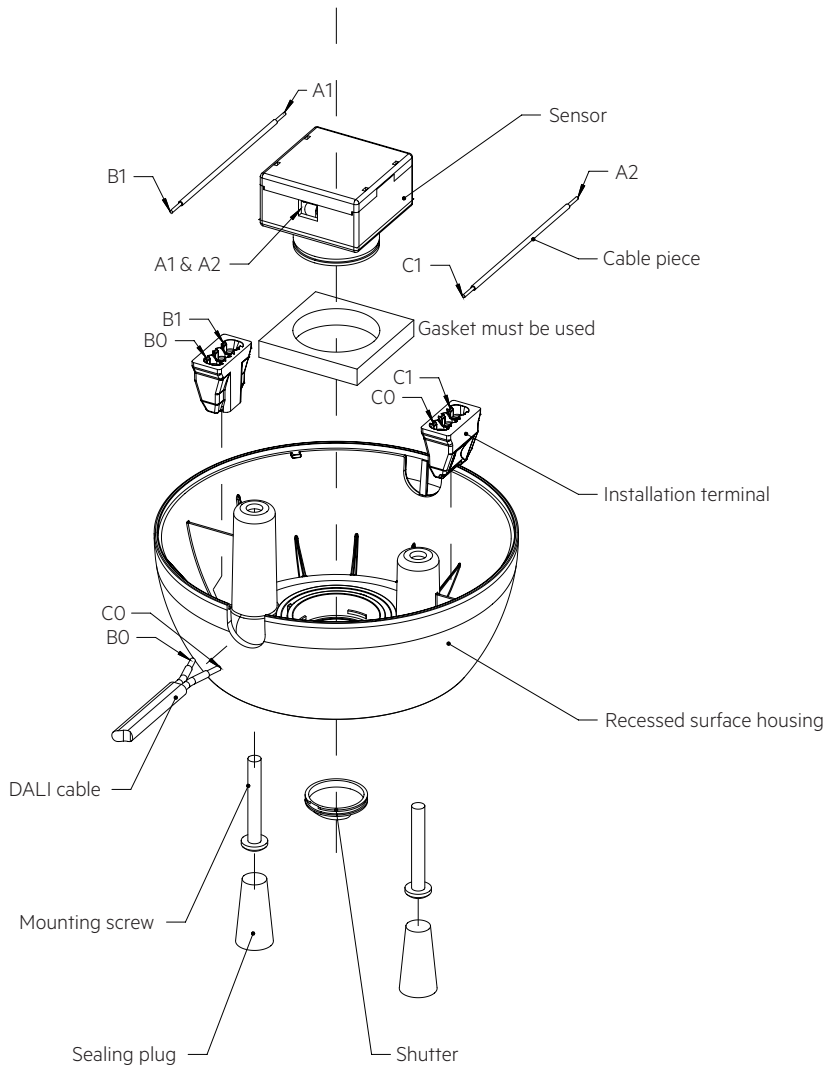

Top view

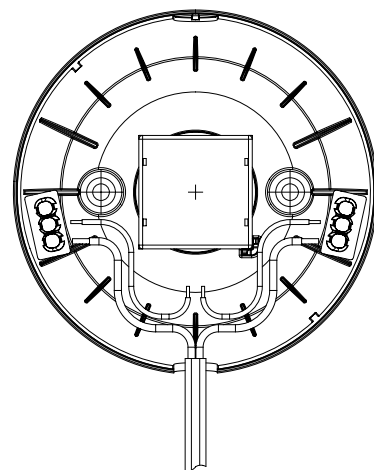

### 3.4 Detection area covers

Included in each ACU SHADING SET 034 4DPI WDA there are 3 detection area covers included.

Type of material: Lexan 923  
 Colour: transparent  
 Surface finish: polished

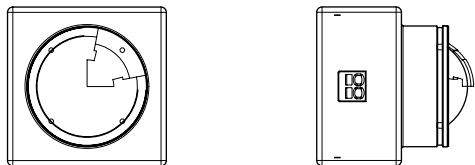

Attach the detection area cover to the sensor by inserting it into the corresponding groove at the front of the sensor.

Shutters made for one time use, once installed removal may damage the shutter and sensor lens!

If you install a damaged shutter to the sensor the risk is high that the shutter falls off!

Area which is masked by the shutter:

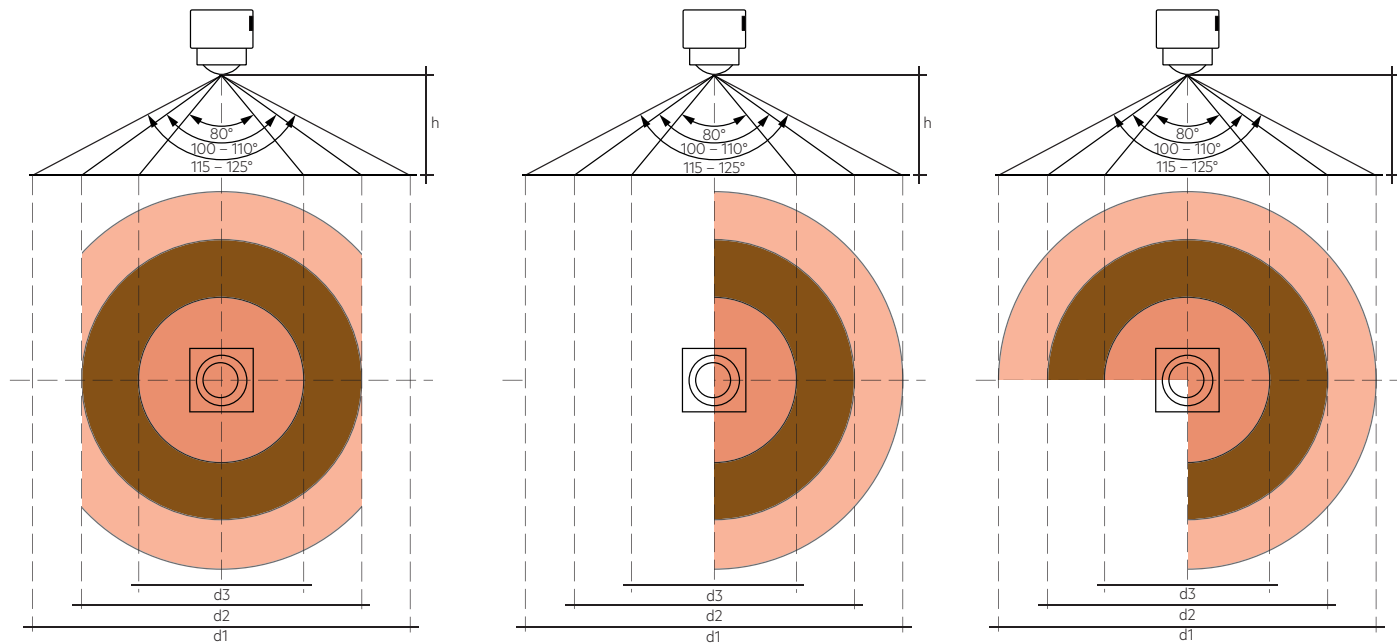
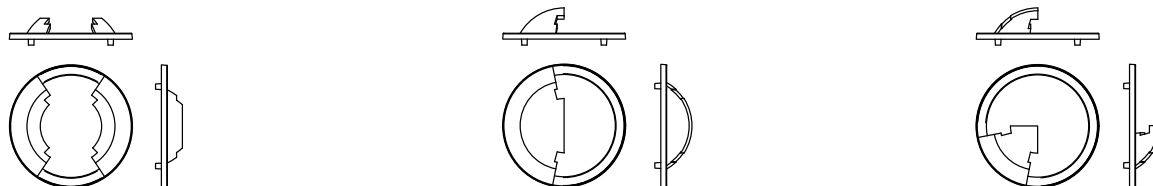

### 3.5 Mounting ring

Included in each Sensor mounting kit ACU 030 IP66 WH and kit ACU 033 IP66 WH is a mounting ring. This ring allows to mount the sensor into a luminaire in an easy and visual attractive way.

3,7 for ACU 030  
 3 for ACU 033

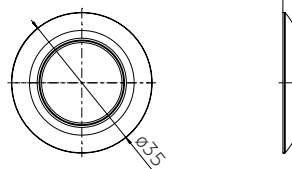

### 3.6 Gasket

To fulfill ingress protection different gaskets are included in the Mounting Kit. The gaskets are necessary to ensure ingress protection as well as proper mounting of the sensor in luminaire.

Sensor can be inserted into luminaires with a cover size from 0.75 up to 4.0 mm.

According to the size of luminaire cover in certain application, one of the gaskets must be used and mounted between the front of the sensor and the luminaire housing. It is not allowed to use a combination of e.g. two gaskets, because this will not provide the right amount of sealing and you may run in to a risk to not reach the IP54 requirements.

 Use maximum possible size for your application to ensure a proper fit and protection.

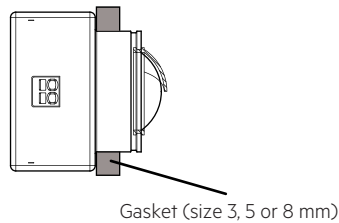

#### Sensor mounting kit ACU 030 IP66 WH

Distance between Sensor and luminaire	Final size of gasket after assembly	Use gasket
2.0 – 2.4 mm	2.0 – 2.4 mm	3 mm
2.5 – 4.0 mm	2.5 – 4.0 mm	5 mm
4.0 – 5.9 mm	4.0 – 5.9 mm	8 mm

#### Sensor mounting kit ACU 033 IP66 WH

Distance between Sensor and luminaire	Final size of gasket after assembly	Use gasket
2.7 – 4.0 mm	2.7 – 4.0 mm	5 mm
4.0 – 5.9 mm	4.0 – 5.9 mm	8 mm

### 3.7 Ingress protection

This device contains IP-protection to use it also in applications with the need of protection against dust and water ingress. IP54 protection applies to the front of the sensor whereas the back of the sensor is IP20 rated.

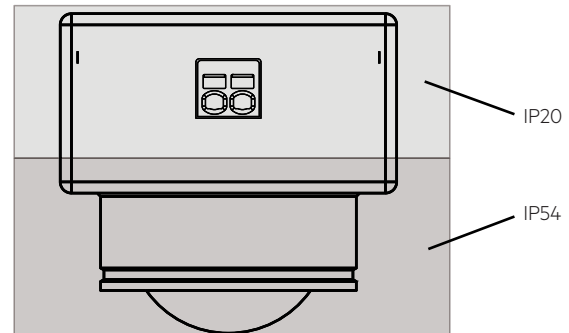

 Only valide for SFI version. SSM and SRC version are only IP20 protected.

### 3.8 Mounting in class II luminaire

The Sensor provides basic insulation as required by IEC 62386-101 and defined in IEC 61347-1.

If the sensor is built in to a class II luminaire which has to provide double or reinforced insulation it has to be considered that the Sensor is not a class II device. Still the Sensor can be used for such projects as the most part of the sensor is tested to fulfil the class II requirements for double or reinforced insulation. Basic insulation is illustrated in the graphic below and covers an area 2,5 mm around the terminal.

The rest of the sensor fulfils class II requirements.

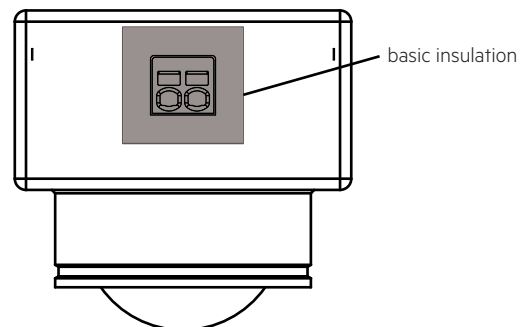

#### 4. Sensor function

##### 4.1 Occupancy / motion detection

For occupancy detection PIR technology is used. The PIR Lens is made to detect moving people in areas such as office, open space or corridors with the following performance criteria:

- Ceiling height from 2 up to 4 m
- Movement of human body
- Center area with increased sensitivity to detect small movements with speed  $\geq 0.5$  m/s for mounting heights up to 3 m (80° full angle)
- Movement speed  $\geq 1.0$  m/s for mounting heights up to 4 m



Reaction time of the sensor (time between occupancy detected and event information send to DALI Bus) is  $\leq 25$  ms.

The reaction time of the system can be extended by factors such as the amount of data on the bus, the number of connected devices or the control device used (Application Controller).

The point at which the light responds must therefore not be equated with the outer detection range.

##### 4.2 Detection area

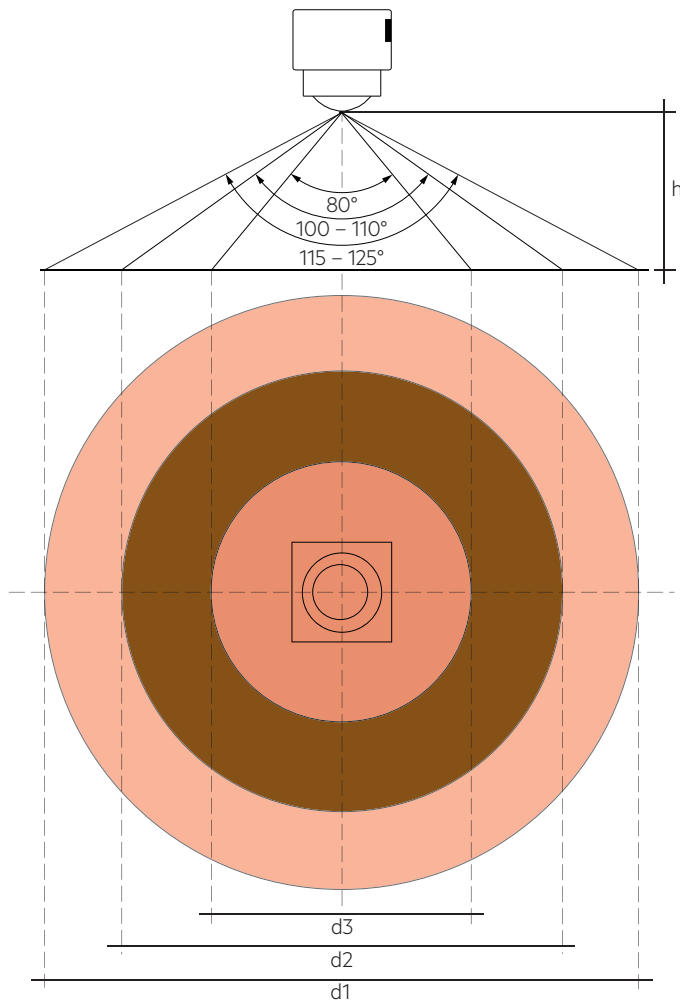

h = Height	d1 = Tangential movements		d2 = Radial movements		d3 = Small movements	
	Full angle	Diameter	Full angle	Diameter	Full angle	Diameter
2.0 m	125°	7.7 m	110°	5.7 m	80°	3.4 m
2.5 m	125°	9.6 m	110°	7.1 m	80°	4.2 m
3.0 m	125°	11.5 m	110°	8.6 m	80°	5.0 m
3.5 m	125°	13.4 m	110°	10.0 m	-	-
4.0 m	115°	12.6 m	100°	9.5 m	-	-

Schematic illustration of radial / tangential movements:

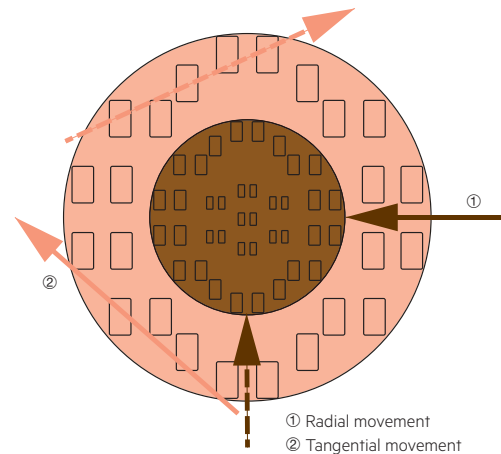

- ① Radial movement
- ② Tangential movement

Detection example at 2.5 m mounting height:

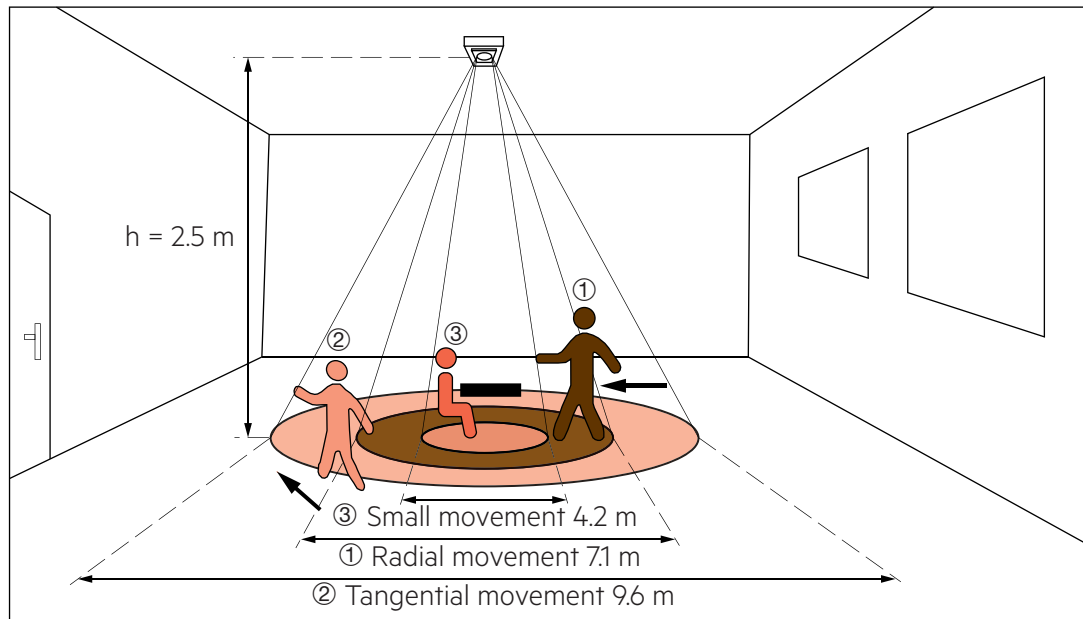

### 4.3 Light measurement

The light measurement has a cone-shaped detection area with a half angle of approximately 75° in x-direction and 40° in y-direction.

Pay attention on the position of the sensor!

The detection area is asymmetrical and the position of the sensor makes a difference which area reflection is used for the light measurement.

The terminal of the sensor is visualized in the graphic and can be used for orientation of the direction.

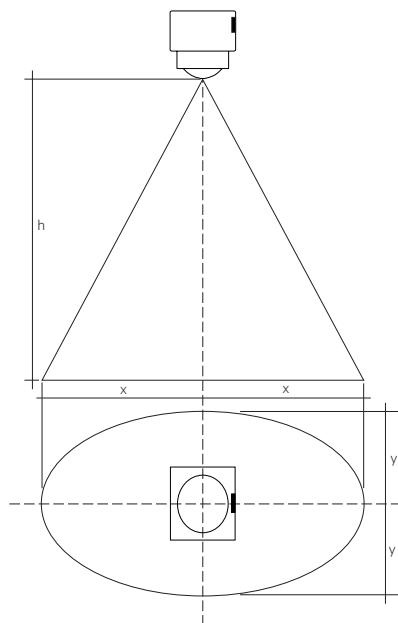

h	dx	dy
2 m	3.0 m	1.5 m
3 m	4.6 m	2.2 m
4 m	6.1 m	2.9 m

The measurement range is between 0.5 and 2000 lx. Measured at the sensor head.



To be able to measure values < 5 lx in an accurate way it is needed to change integration time of light sensor to 800 ms. Integration time of light sensor is set to 100 ms by default. For values > 5 lx there is no difference in between these measurements.

### 4.4 Status LED's

There is a LED built in to indicate different status information to the user.

Event	Blinking sequence	LED Color
DALI command „identify device“	500 ms on / 500 ms off for 10 s	Red
Motion detection <sup>①</sup>	Default deactivated but can be activated by the application controller. If active, 1000 ms on every time Motion is detected.	Red
IR-Signal received <sup>①</sup>	Double blinking (150 ms on / 150 ms off) on every received IR-command.	Red

Light measurement priority

① By default, these blinking patterns are interrupted by the light measurement, because the light measurement has a higher priority.

This behavior can be changed via the application controller, i.e. it can be configured that the blinking patterns are carried out, regardless of an ongoing light measurement. Consequently, the accuracy of the light measurement will become worse, because the brightness of the LED distorts the measurement.

### 4.3.1 Light value format

The default operating mode is 128.

In this mode the user is able to choose from fixed point and floating point values for the light measurement. The default setting are floating point values.

In addition to operation mode 128 also operating mode 0 is implemented.

In operating mode 0 the fixed point values are supported for the light measurement values.

Resolution for fixed point and floating point = 1/64 Lux

### 5. Configuration

Optimized for the operation in conjunction with the Tridonic application controller sceneCOM S.

For commissioning and configuration the App „sCS commissioning“ (sceneCOM S) is provided by Tridonic. App can be installed on iOS and Android devices. Compatible with Android 6.0 / iOS 10 or later, devices with a min. screen size of 20 cm diagonal and a min. resolution of 1024 x 768 pixels.

Android:



iOS:



### 6. Miscellaneous

#### 6.1 Disposal of equipment



Return old devices in accordance with the WEEE directive to suitable recycling facilities.

#### 6.2 Additional information

Additional technical information at [www.tridonic.com](http://www.tridonic.com) → Technical Data

Guarantee conditions at [www.tridonic.com](http://www.tridonic.com) → Services

Lifetime declarations are informative and represent no warranty claim. No warranty if device was opened.